

BUILDING PERMIT REQUIREMENTS FOR:
RESIDENTIAL
ROOM ADDITIONS & REMODELS

INFORMATION
GUIDELINE

11

Jan 2017

CITY OF ESCONDIDO • BUILDING DIVISION • 201 N. BROADWAY, ESCONDIDO, CA 92025 • (760) 839-4647

SAMPLE PLANS

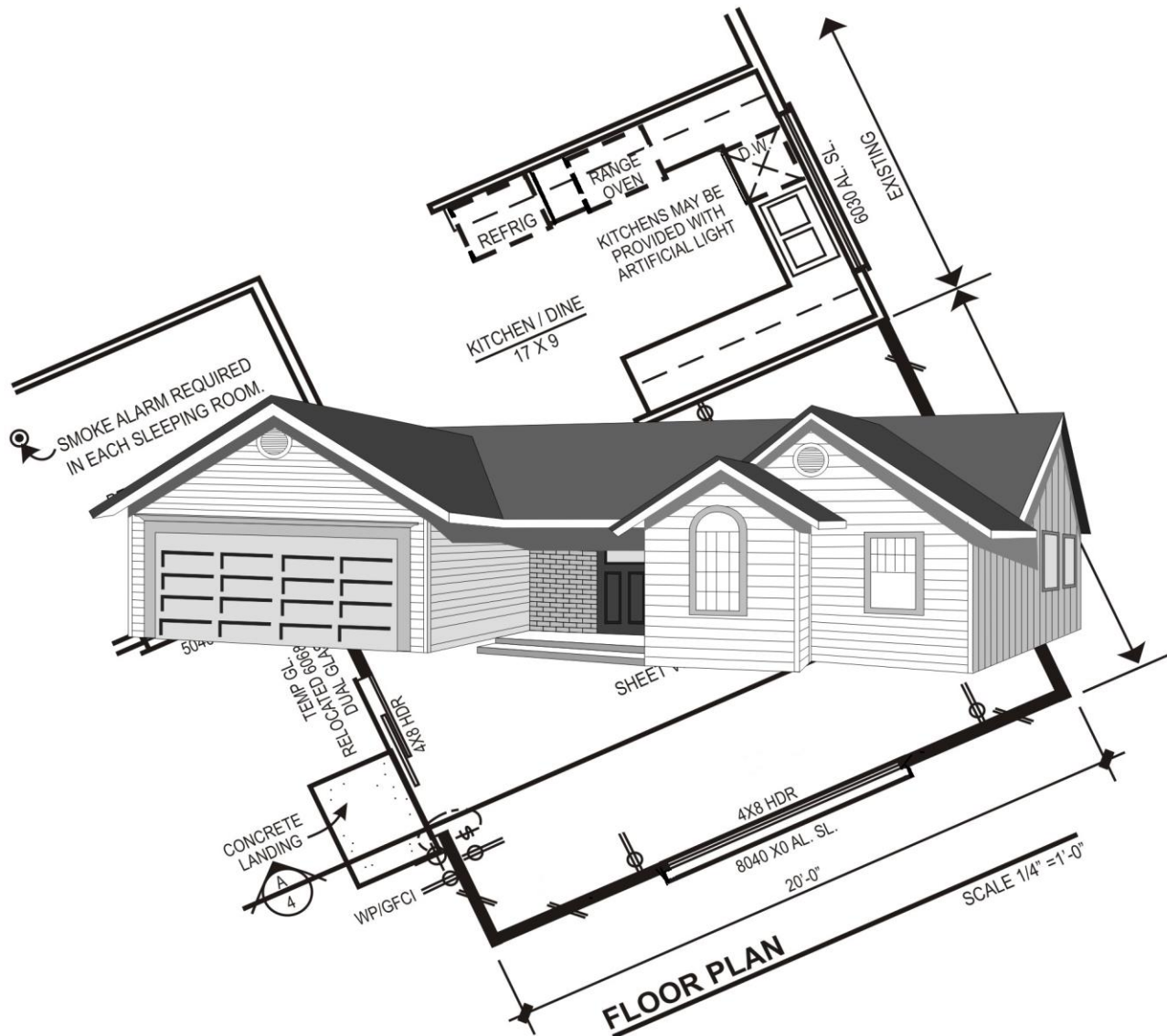

Bedroom Egress Requirements

- 5.7 sf net clear opening (grade level openings 5.0 sf)
 - 20" minimum clear width
 - 24" minimum clear height
 - 44" maximum sill height from floor
1. Check Master Bedroom. 8% of Floor Area for natural light, 4% natural ventilation.
 Room area = (190 sf natural light required) x .08 = 15.2 sf
 Natural ventilation required: 190 sf x .04 = 7.6 sf.
 Provided 5040 XO SL or (Minimum 4040 XO SL)
 Window area = 20 sf natural light and ~ 10 sf natural ventilation.
 Also meets egress requirements.
 2. Check existing Bedroom. 102 sf; 8.16 sf natural light required, 4.08 sf natural ventilation required. However, egress requirements supercede light and ventilation minimum requirements.
 A 5040 XO SL as shown or 4040 XO SL may be used or another window or door that will meet all minimum requirements. Verify egress dimensions with window manufacturer.

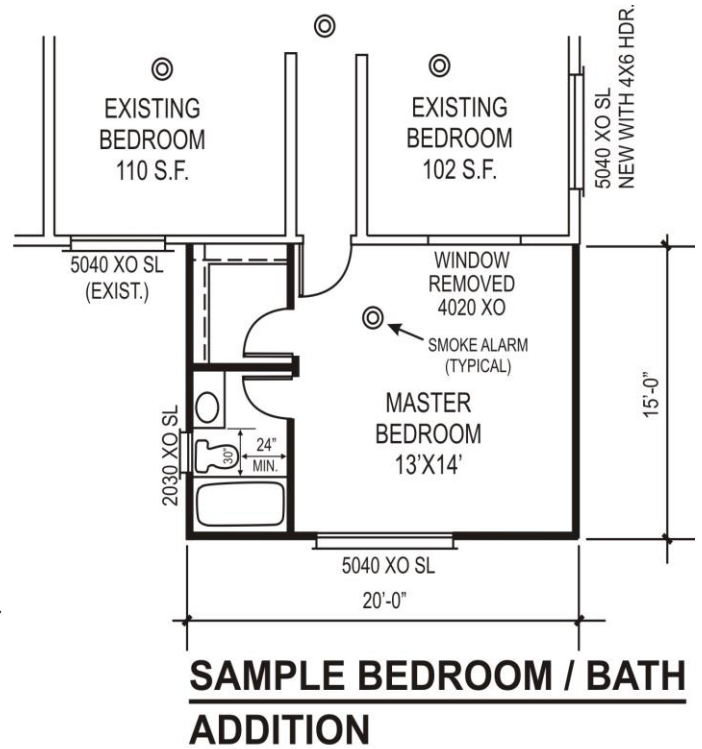

Light and Ventilation for Adjoining Rooms

Per CRC Section R303.2, for the purposes of determining the light or ventilation required, any room may be considered as a portion of an adjoining room when one-half the common wall is open and unobstructed and provides an opening at least one-tenth (for natural light), and 8% (ventilation), of the floor area of the interior room, or 25 sf whichever is greater.

Family Room adjoining Dining Room

1. One-half of the common wall, 13'x8'=104sf/2=52 sf required opening.
 Enlarge opening where the 6050 window was removed to provide the minimum 50% requirement.
2. Window size at the Family Room [276 sf] +Dining Room [145 sf] = 421 sf/10 = 42.1 sf natural light and 21.05 sf natural ventilation meets 8% requirement
 Various combinations available,
 Try: 10' x 5' XO SL window=50 sf
3. The 2668 opening does not provide the required 50% opening between the Kitchen and Family Room and is not considered as providing the natural light or natural ventilation for code purposes.

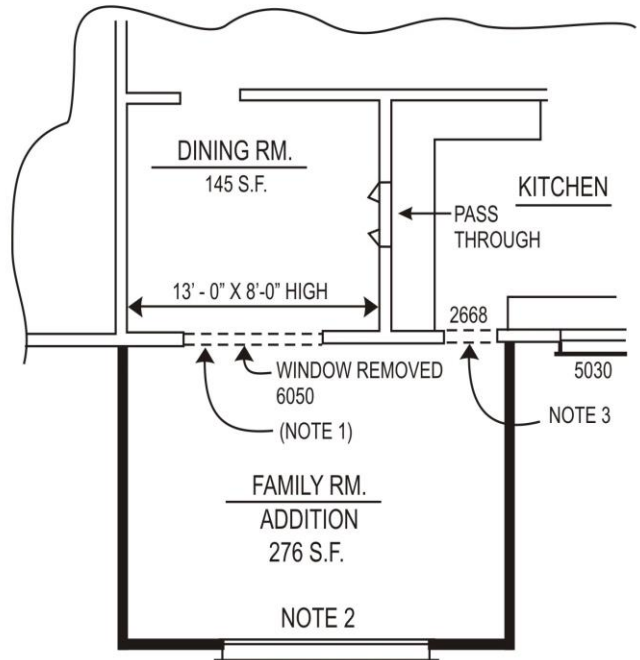

SAMPLE NOT FOR CONSTRUCTION PURPOSES

MAIN STREET

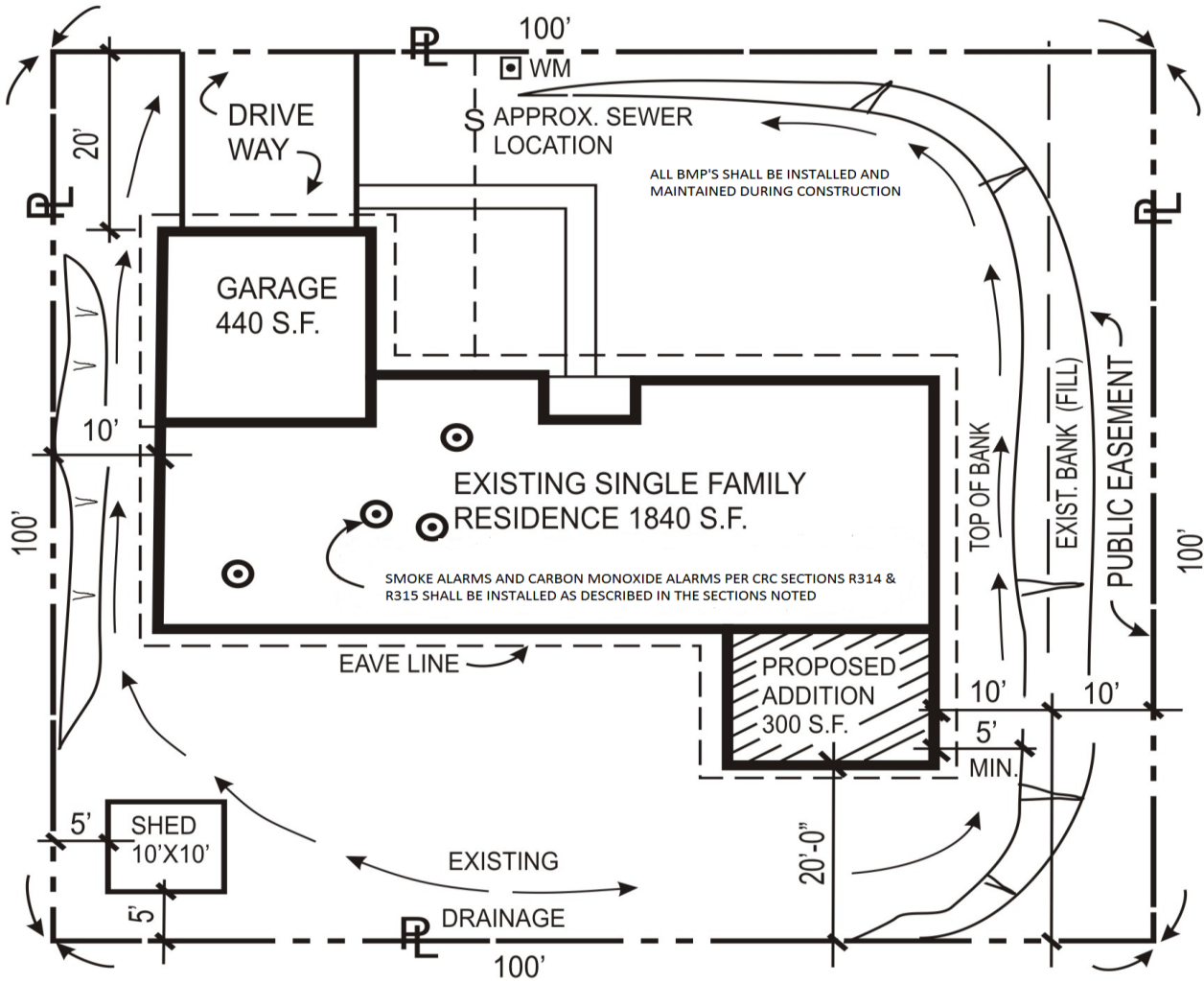

PLOT PLAN

SCALE 1"=20'

LEGAL DESCRIPTION: LOT 10, MAP 8546

ASSESSORS PARCEL NO

547-091-0500

OWNER
JOHN DOE
1011 MAIN
ANYWHERE, CA

PLANS DRAWN BY:
J.A. SMITH
423 BROADWAY
ANYWHERE, CA.

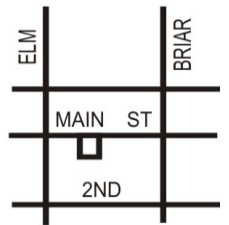

VICINITY MAP

NOTE: BEST MANAGEMENT PRACTICES (BMPs) MUST BE USED AT ALL CONSTRUCTION SITES IN THE CITY TO PROTECT STORM DRAINS AND MINIMIZE POLLUTION.

ENERGY CALCULATIONS ARE NOT-A-PART OF THIS GUIDELINE. COMPLIANCE WITH C.C.R. TITLE 24, PART 6, CALIFORNIA ENERGY CODE IS REQUIRED AT PLAN CHECK SUBMITTAL.

SHEET 1

SAMPLE NOT FOR CONSTRUCTION PURPOSES

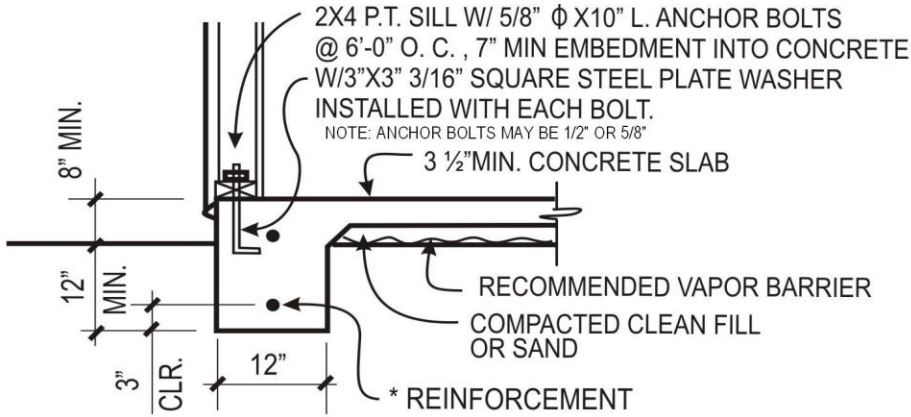

* FOOTING STEEL REINFORCEMENT
 EITHER 1- #4 ϕ TOP & BOTTOM
 (FOR TWO POUR) OR;
 1- #5 ϕ TOP OR BOTTOM WHEN
 SLAB CAST MONOLITHIC WITH FOOTING.

FOOTING DETAIL - TYPICAL EXTERIOR

SCALE : 1/2" = 1'-0"

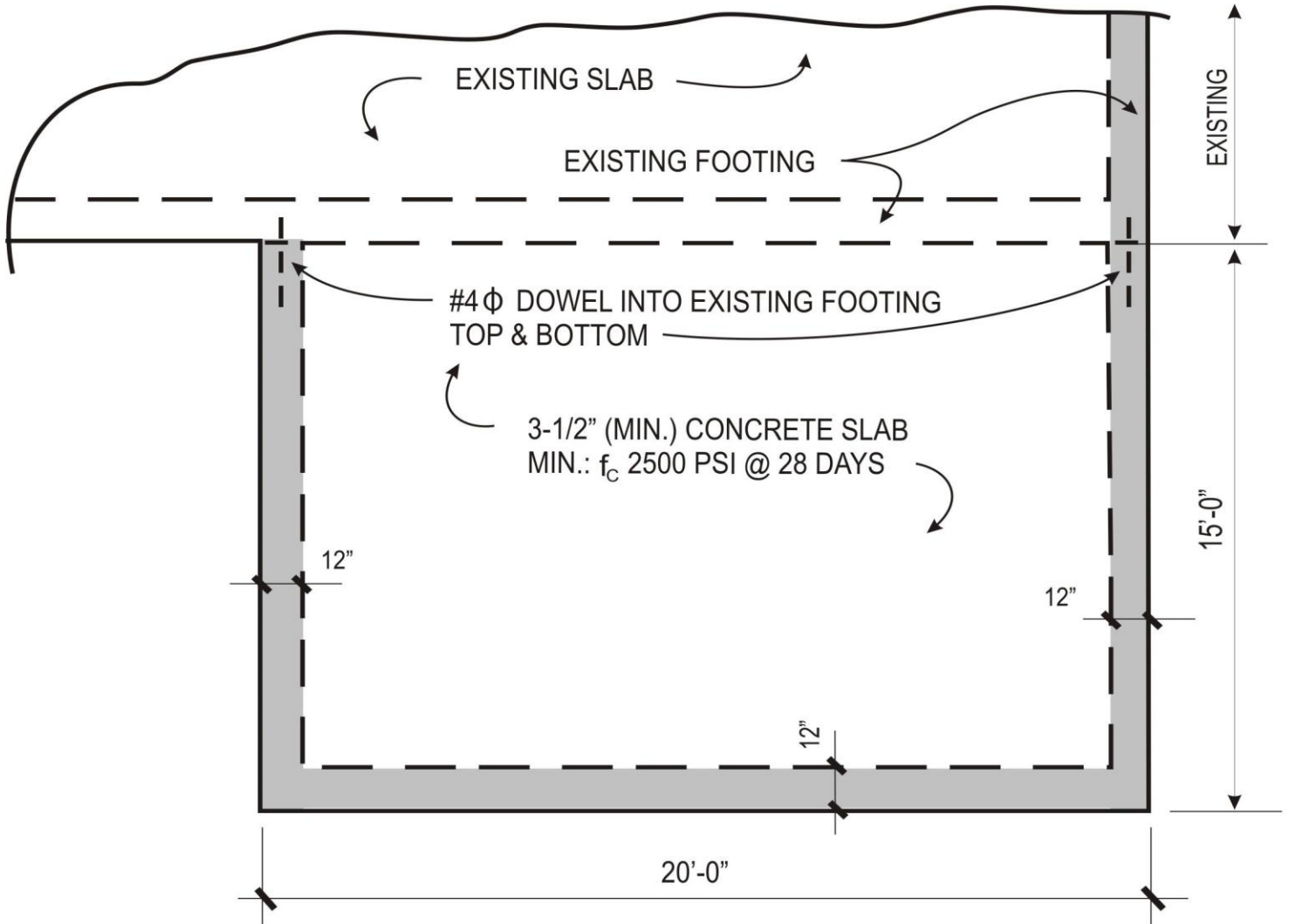

FOUNDATION PLAN

SCALE : 1/4" = 1'-0"

SHEET 2

SAMPLE NOT FOR CONSTRUCTION PURPOSES

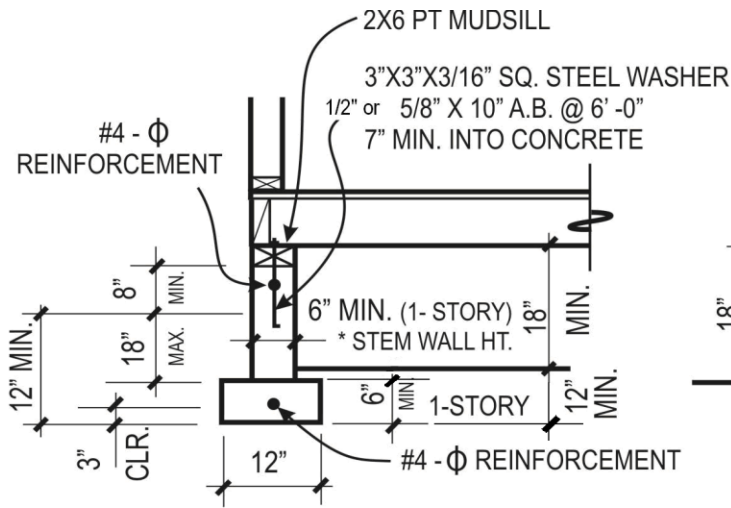

FOOTING

DETAILS
1/2" = 1'-0"

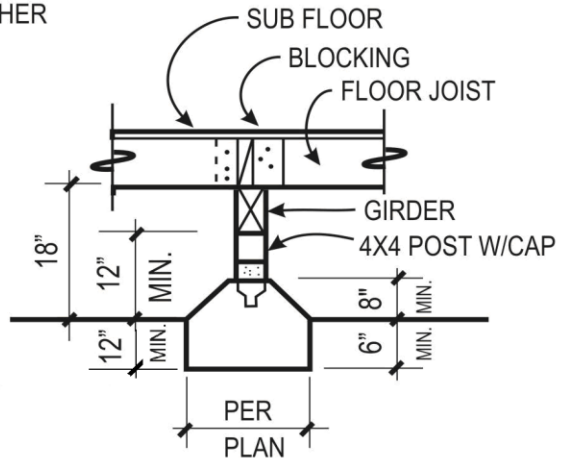

PIER

(SIZE BASED ON LOADS)

* STEM WALL: CONCRETE OR UN-REINFORCED SOLID GROUTED MASONRY. HEIGHT MAY BE MAX. 6 TIMES THICKNESS AS SHOWN. REF S.D.NEWSLETTER 18-4 & 18-5

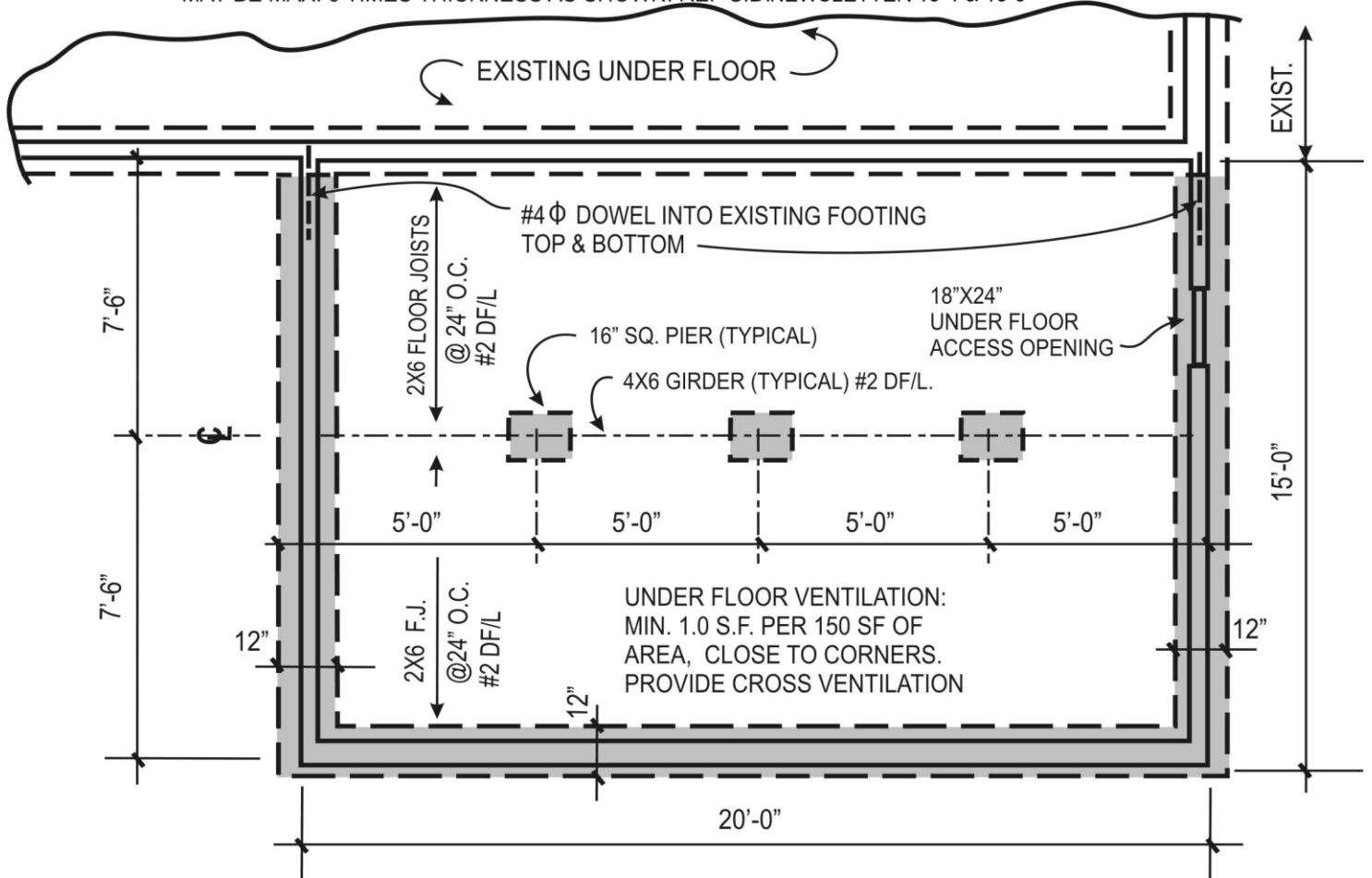

"RAISED FLOOR" - FOUNDATION PLAN

(ALTERNATE EXAMPLE)

SCALE 1/4" = 1'-0"

REFER TO CRC SECTION R405 FOR FOUNDATION DRAINAGE

SHEET 2 A

SAMPLE NOT FOR CONSTRUCTION PURPOSES

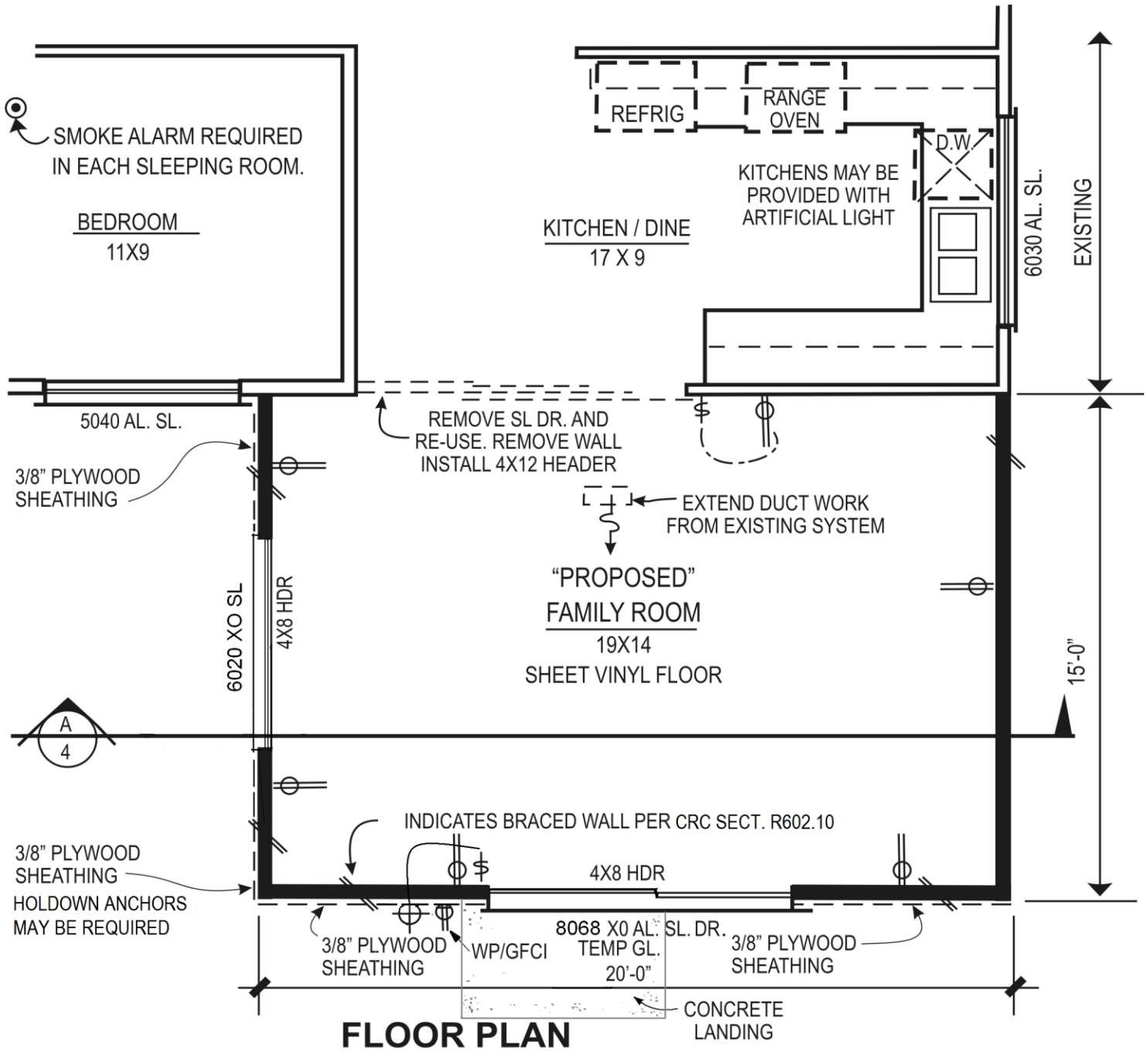

SCALE 1/4" = 1'-0"

WALL KEY

- EXISTING WALL
- NEW WALL
- WALL REMOVED

EXISTING HOUSE: 1840 S.F.
 PROPOSED ADDITION: 300 S. F.
 TOTAL HOUSE: 2140 S. F.

SHEET 3

SAMPLE NOT FOR CONSTRUCTION PURPOSES

NOTE: 1. ENERGY COMPLIANCE DOCUMENTAION IS REQUIRED AT PLAN CHECK SUBMITTAL.

2. THIS GUIDELINE DOES NOT APPLY TO STRUCTURES LOCATED IN HIGH OR VERY HIGH FIRE SEVERITY ZONES.

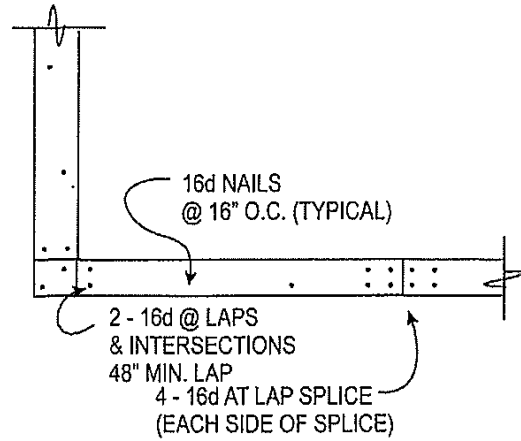
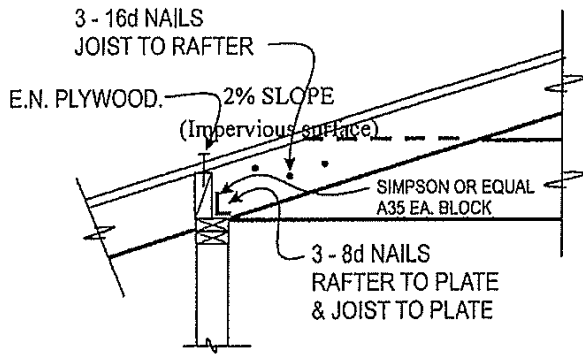

TYPICAL EAVE JOINT DETAILS **TOP PLATE CONNECTION**

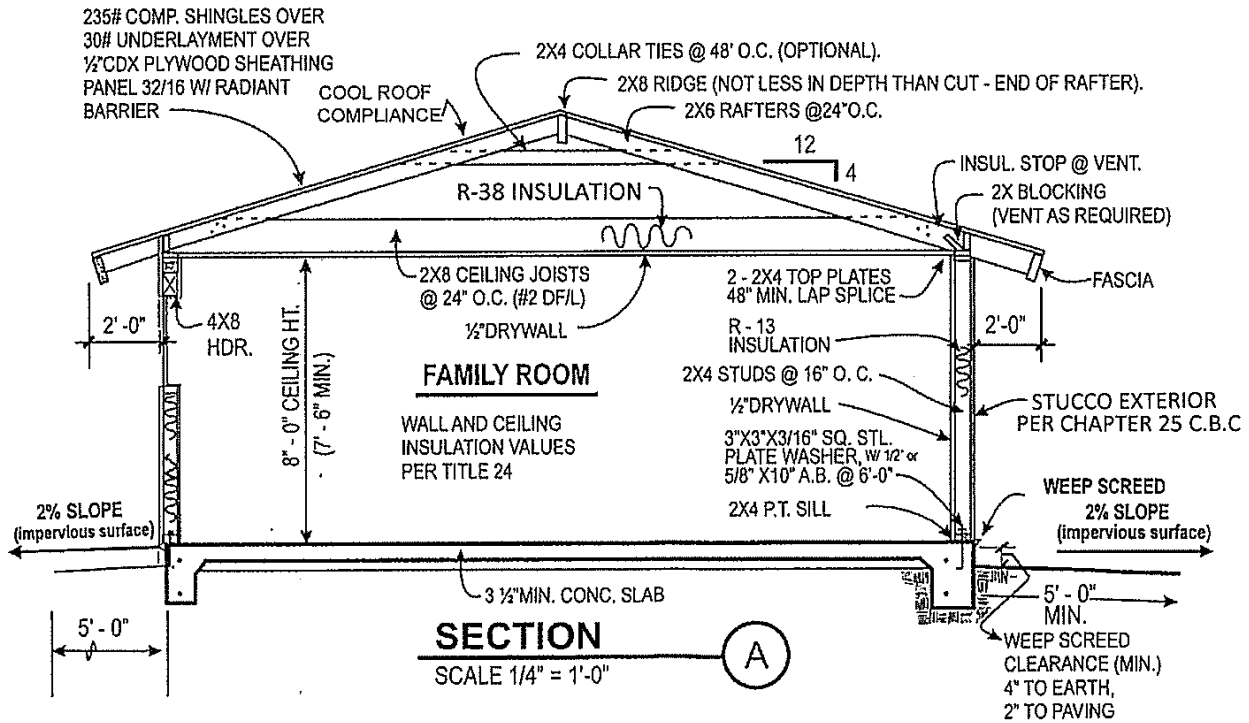

SHEET 4

SAMPLE NOT FOR CONSTRUCTION PURPOSES

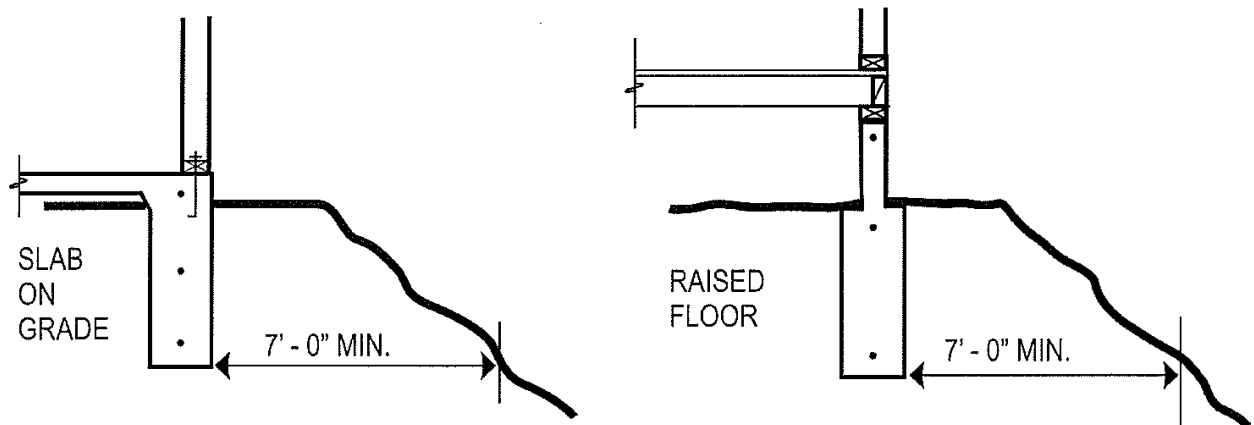

FOOTINGS ADJACENT TO SLOPE

SEE SECTION
FOR NOTES

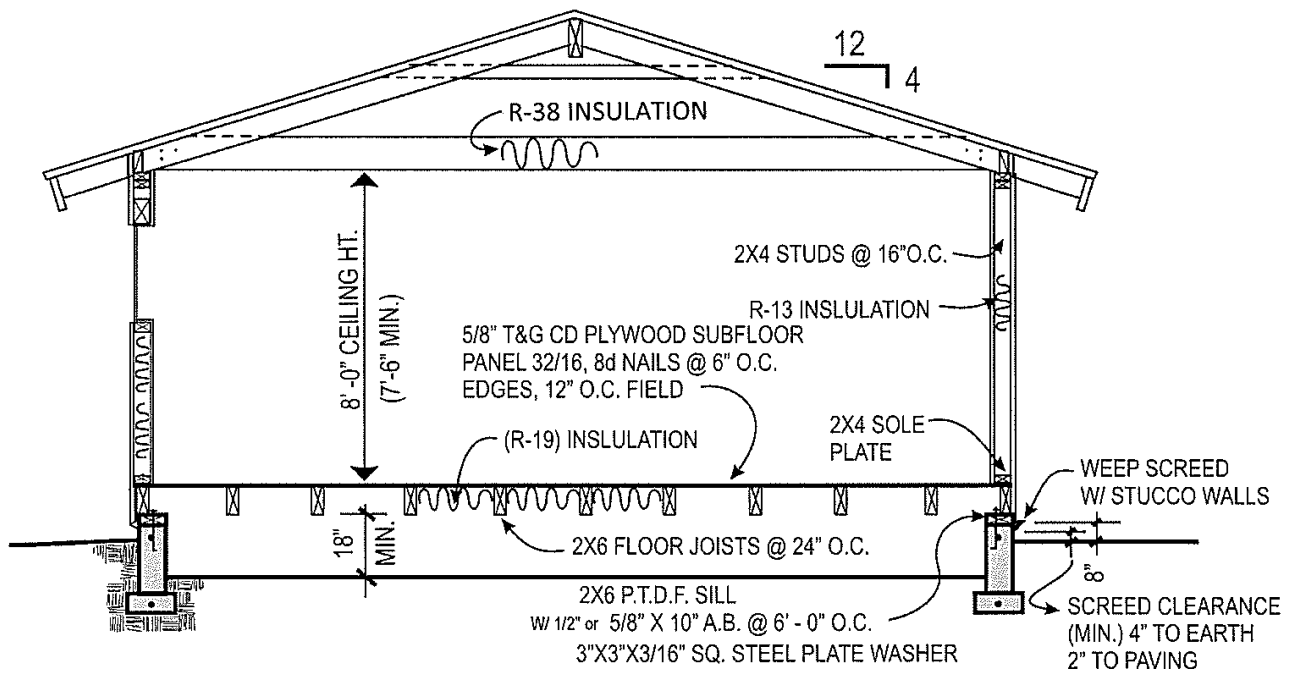

AT DOOR

SECTION



"RAISED FLOOR"

SCALE 1/4" = 1'-0"

SHEET 4A

SAMPLE NOT FOR CONSTRUCTION PURPOSES

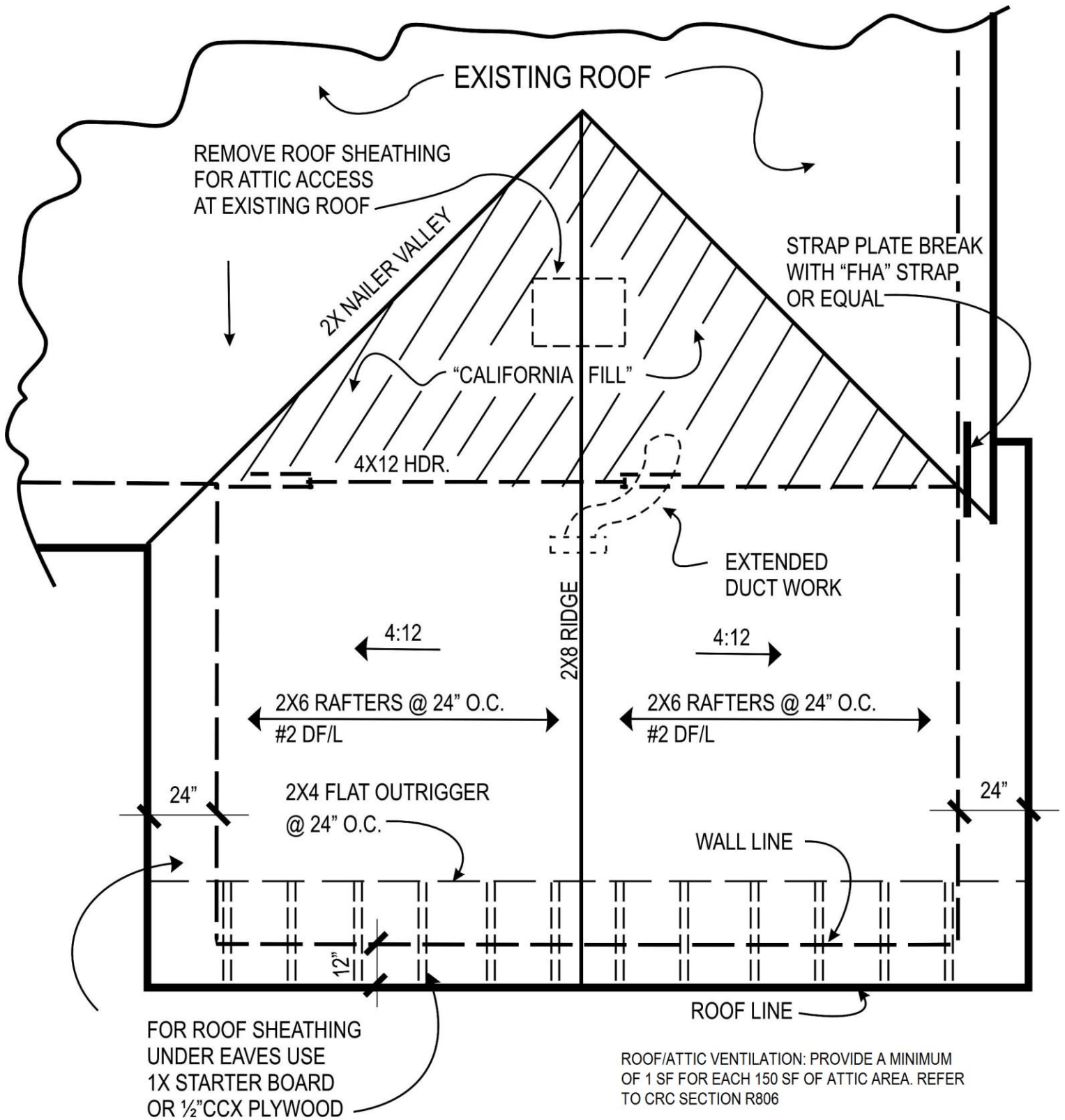

ROOF (FRAMING) PLAN

SCALE : 1/4" = 1'-0"

SAMPLE NOT FOR CONSTRUCTION PURPOSES

SHEET 5

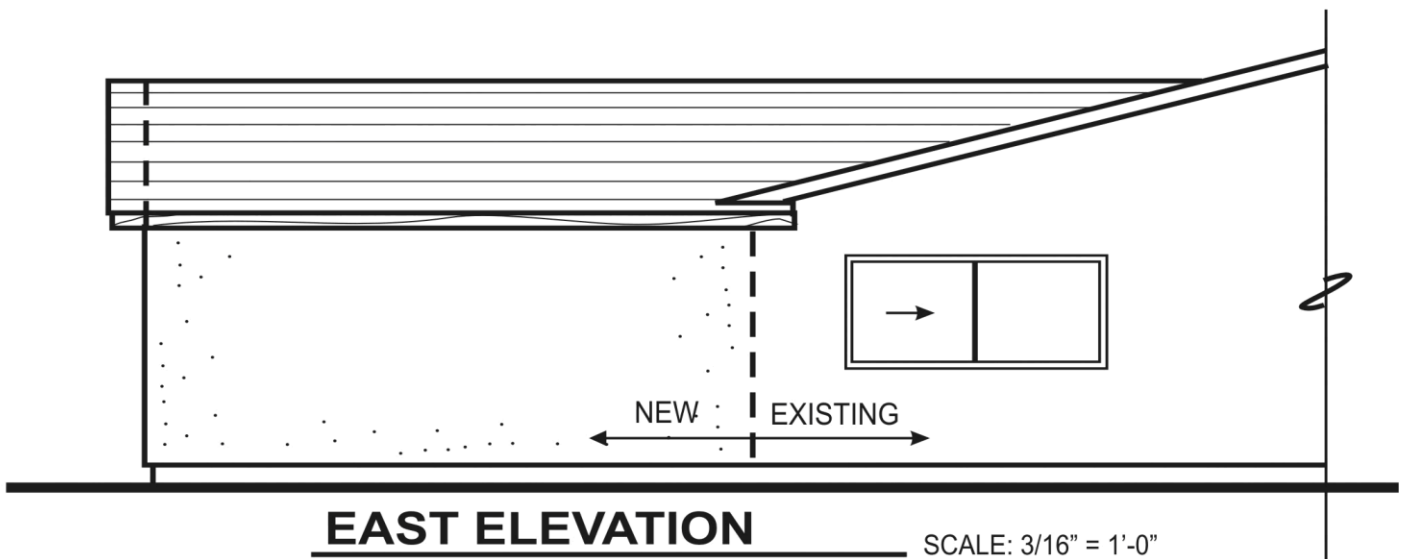
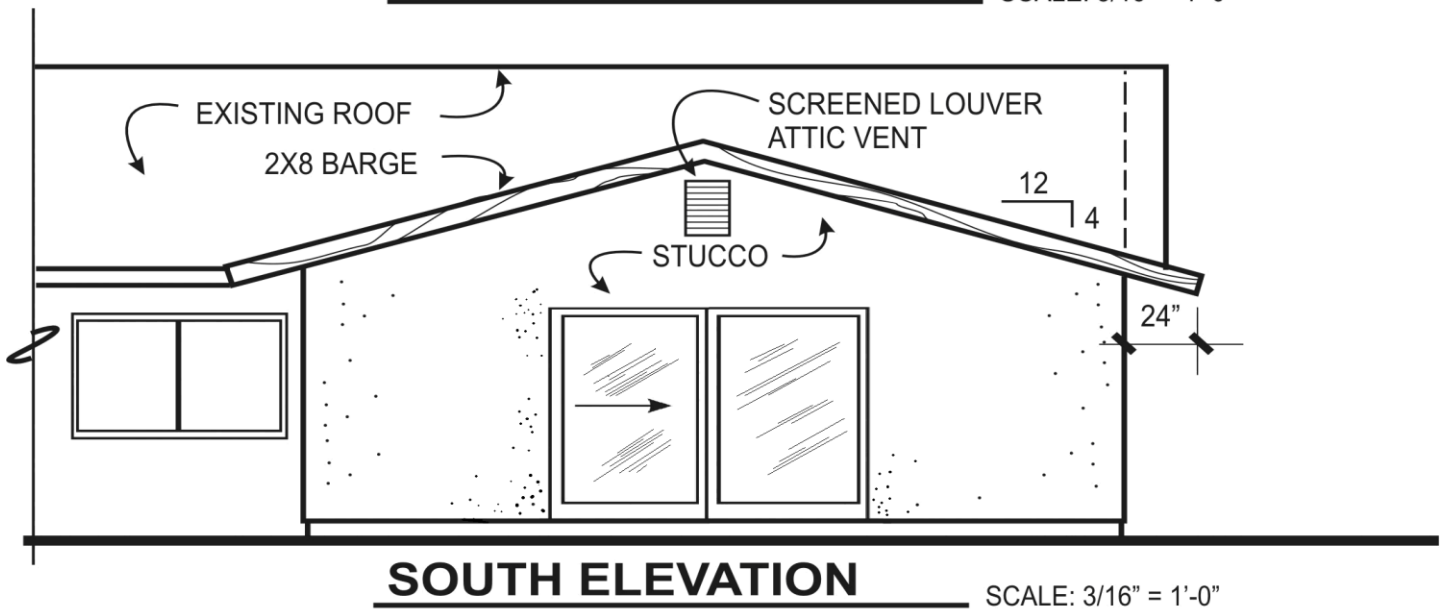
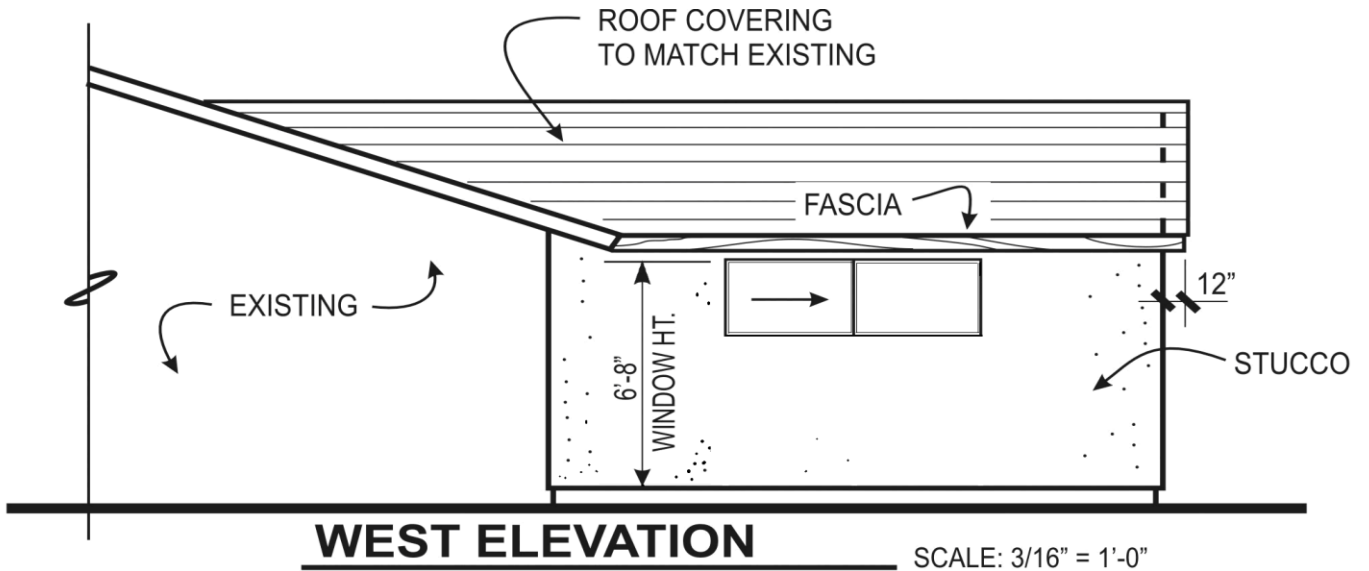

SHEET 6

SAMPLE NOT FOR CONSTRUCTION PURPOSES