

**CITY OF ESCONDIDO**

**TECHNICAL PROVISIONS FOR CONSTRUCTION OF**  
**TRAFFIC SIGNALS AND SAFETY LIGHTING,**  
**ROADWAY MARKINGS, AND SIGNING**

(For these Technical Provisions **ONLY**) Approved on: Ali Shahzad 6.29.10

By: Ali Shahzad, PE (Traffic)

**Associate Engineer**



**TECHNICAL PROVISIONS FOR CONSTRUCTION OF**  
**TRAFFIC SIGNALS AND SAFETY LIGHTING,**  
**ROADWAY MARKINGS, AND SIGNING**

**1.) DESCRIPTION OF WORK**

The work governed by these Technical Provisions consists of furnishing and installing, modifying, salvaging, and/or relocating traffic signals, street lighting systems, flashing beacons, signs, and roadway markings (including raised pavement markers); and other ancillary work shown on the Plans. Said work shall conform to the provisions in

- (a.) Section 86, "SIGNALS, LIGHTING, AND ELECTRICAL SYSTEMS";
- (b.) Section 84, "TRAFFIC STRIPES AND PAVEMENT MARKINGS";
- (c.) Section 85, "PAVEMENT MARKERS";
- (d.) Section 56, "SIGNS"; and
- (e.) Section 15, "EXISTING HIGHWAY FACILITIES";

of the Caltrans Standard Specifications and these Technical Provisions.

**1A.) CITY-FURNISHED EQUIPMENT**

If the signed Plans refer to certain items of traffic signal equipment that have been pre-ordered by the City of Escondido, or are otherwise to be supplied by the City of Escondido, the Contractor shall retrieve said equipment from the Escondido City Maintenance Yard at 475 North Spruce Street, and deliver to the job site. Contractor shall call the Electrical Services Supervisor (Daniel Young, (760) 839-4668 ext. 4885) at least two full working days prior to intended pick-up time and shall coordinate with and cooperate with same regarding retrieval of this material.

Contractor shall be responsible for and shall exercise due care and diligence in loading, transporting, unloading, and mounting any City-supplied equipment mentioned above. Any equipment damaged by the Contractor's operations shall be repaired or replaced at the Contractor's expense.

**2.) EQUIPMENT LIST AND DRAWINGS**

Equipment list and drawings of electrical equipment and material shall conform to the provisions in Section 86-1.04, "EQUIPMENT LIST AND DRAWINGS," of the Caltrans Standard Specifications and these Technical Provisions.

The Contractor shall furnish a maintenance manual and an operations manual for all controller assembly units, auxiliary equipment, vehicle detector sensor units, control units and amplifiers which are to be supplied as a part of this contract. The maintenance manual and operations manual may be combined into one manual. The maintenance manual or combined maintenance and operations manual shall be submitted at the time the equipment is delivered for testing or, if ordered by the Engineer, prior to purchase. The maintenance manual shall include, but need not be limited to, the following items:

- A. Specifications
- B. Design Characteristics
- C. General Operation Theory
- D. Function of all Controls
- E. Troubleshooting Procedure (diagnostic routine)
- F. Block Circuit Diagram
- G. Geographical Layout of Components
- H. Schematic Diagrams
- I. List of Replaceable Component Parts with Stock Numbers

3.) **SCHEDULING OF WORK**

Scheduling of work shall conform to the provisions in Section 86-1.07, "SCHEDULING OF WORK," of the Caltrans Standard Specifications and these Technical Provisions.

The construction of new or modified signals, when performed in conjunction with roadway or other improvements, shall be coordinated with said other work to minimize the downtime of the existing signals or intersection control devices.

Traffic signals shall not be placed into operation on a Friday, Saturday, or Sunday.

The Contractor shall schedule work to accommodate those special events and holidays noted in these Special Provisions or specified by the Engineer at the preconstruction conference.

Any restrictions upon closure of driveways stated elsewhere in these Technical Provisions or in the Encroachment Permit shall also apply to all phases of furnishing, installing, and/or modifying traffic signals and safety lighting. Said restrictions shall have same force and effect as though fully restated herein.

No shutdowns of existing traffic signals will be permitted during peak commuter and / or school arrival / dismissal times, as determined by the Public Works Inspector.

New traffic signal poles and equipment thereon shall be installed and operational prior to disconnection and disassembly of existing traffic signal equipment.

**SPECIAL REQUIREMENTS for scheduling of work and for controlling of vehicular, bicycle, and pedestrian traffic** may be required by the Field Engineering Inspector due to the high volumes thereof associated with the proximity of certain school(s). If so directed, the Contractor must adhere to additional precautions during the peak traffic-volume times of 7:00 a.m. to 8:00 a.m. and 2:00 p.m. to 3:00 p.m.

1. All existing sidewalks and walkways shall remain open and unobstructed at all times.
2. Access to passenger loading zones must be maintained during peak times.
3. No lane closures will be permitted during said peak times, except with the advance permission of the Field Engineering Inspector. Said permission may be revoked if problems of unforeseen type / magnitude result.
4. All lane closures must be in accordance with a separate Traffic Control Plan, subject to the restrictions above and subject to the approval of the Field Engineering Inspector.

### 3.1.) **TIMELY REPAIR OF DAMAGED TRAFFIC SIGNAL EQUIPMENT**

Any Contractor who performs any work in the public right-of-way, who cuts through or otherwise damages existing traffic signal inductive loop detectors, shall within 24 hours provide the City of Escondido Field Engineering Inspector with a SCHEDULE for repair of said loops. Said SCHEDULE shall be subject to review and approval by the City of Escondido.

Contractor shall either replace said inductive loop detectors in kind within 72 hours, or shall furnish, install, and test a video detection system conforming to the requirements of the Section of these Technical Provisions entitled "VIDEO DETECTION" within the time specified in the City-approved SCHEDULE. If it is known in advance that a particular phase of work will damage inductive detector loops, the Contractor will be required to furnish, install, and test the video detection system PRIOR to beginning said phase of work. If the condition of the existing asphalt concrete pavement is not suitable for re-installation of inductive loop detectors, in the opinion of the Field Engineering Inspector, the contractor shall only have the option of installing video detection.

If the Contractor fails to respond within the time frame of the City-approved SCHEDULE, the City of Escondido shall have the right to restore signal detection, either with loops or video as it sees fit, and charge all costs therefor, including

administrative costs, to any monies due or deposits / bonds placed by the Contractor. The Contractor is ultimately responsible for compensating the City for all damages, and all additional costs associated therewith, caused by the damage to traffic signal equipment.

Any Contractor who performs any work in the public right-of-way, who cuts through or otherwise damages existing underground traffic signal and / or lighting conduits, including service and communication / interconnect conduits, shall within 24 hours provide complete and permanent repair of said conduits, including conductors therein if severed / damaged. Splices in conductors will not be allowed as a permanent repair.

If the Contractor fails to respond within the time frame specified above, the City of Escondido shall have the right to restore operation of the damaged signal / lighting conduit / conductors, and charge all costs therefor, including administrative costs, to any monies due or deposits / bonds placed by the Contractor. The Contractor is ultimately responsible for compensating the City for all damages, and all additional costs associated therewith, caused by the damage to traffic signal equipment.

#### 4.) **FOUNDATIONS**

Foundations for traffic signal standards shall conform to the provisions in Section 86-2.03, "FOUNDATIONS," of the Caltrans Standard Specifications and these Technical Provisions.

The locations of all traffic signal standards and cabinets shown on the Plans shall be considered approximate. All locations of signal standards and cabinets proposed on the Plans shall be marked out in the field by a Licensed Land Surveyor per information on the Plans. Said locations are subject to adjustment by the Engineer; the Contractor shall obtain approval of final locations by the Engineer prior to excavation for foundations.. After locations have been established and prior to excavation, the Contractor shall tie-out the approved locations and provide the Engineer with lengths and locations of said ties.

The Engineer of Work has endeavored to show on the Construction Drawings the approximate locations of all public utilities and facilities which may be encountered during construction / modification of Traffic Signals and Safety Lighting. However, in some instances, the intended location of traffic signal pole foundations and controller / meter pedestal cabinet foundations may be very close to or may conflict with underground utilities as marked out by Underground Service Alert (USA). For all traffic signal pole locations and/or cabinet locations where USA mark-out indicates the possibility of conflict, the Contractor shall:

- A. Pot-hole to determine the exact location of ALL potentially-conflicting substructure(s);

- B. Provide dimensions precisely locating said underground conflicts(s) and mark surface improvements directly over said pot-holed utilities;
- C. Allow at least three full working days for Engineer of Work to provide revised pole / cabinet positioning; and
- D. Install pole / cabinet foundation per revised positioning, utilizing hand-digging if and where necessary (in the opinion of the Public Works Inspector) to avoid damaging the substructure(s) with powered equipment.

If any existing irrigation facilities are in conflict with the foundation location, the Contractor shall re-route the irrigation facilities outside of the foundation area. Said re-routing shall preserve, to the extent practical, the functionality of the original irrigation system.

4.1.) **ABANDON STREET LIGHT FOUNDATION(S)**

Where the Plans show existing ornamental street lights to be removed and salvaged or relocated, if the existing street light pole's foundation is in an area that will be paved or have curb and gutter constructed, the foundation shall be removed in its entirety. If the existing foundation is completely outside the traveled way and curb-and-gutter section, the Contractor shall abandon the existing foundation and maintain existing street light circuit continuity per the attached Drawing #4.

4.2.) **SPECIAL FOUNDATION DETAIL FOR 1A POLES**

Certain 1A pole locations may have underground conflicts which may be mitigated by use of a Special Foundation Detail (see attached Drawing #5). The Contractor shall furnish and install said special foundations where needed, in the opinion of the Field Engineering Inspector, per the attached Drawing #5.

5.) **TRAFFIC SIGNAL MAST ARMS**

Traffic signal mast arms shall conform to the provisions in Section 86-2.04, "STANDARDS, STEEL PEDESTALS, AND POSTS," of the Caltrans Standard Specifications and these Technical Provisions.

The 27th paragraph of Section 86-2.04, "STANDARDS, STEEL PEDESTALS, AND POSTS," of the Caltrans Standard Specifications is hereby amended to read;

Changes in configuration of mast arms may be permitted, provided that the mounting height and stability are maintained, and provided that detailed drawings of mast-arm curvature are submitted, subject to the approval of the Engineer.

The 29th paragraph of Section 86-2.04, "STANDARDS, STEEL PEDESTALS, AND POSTS," of the Caltrans Standard Specifications is hereby amended to read:

All arms shall be bent to the approximate configuration shown on the Plans, subject to the following requirements. The curvature of the mast arm shall be distributed evenly over at least 60 percent of the mast arm's total length. When mounted on its standard and fully loaded with all required equipment, the mast arm's angle-to-horizontal shall vary from "theta" (see Standard Plans) to near, but not past, zero (level, horizontal position). Traffic signal mast arms not meeting this requirement will be subject to rejection.

The Contractor shall furnish and install interim-length traffic signal mast arm(s) if / where called for on the Plans. Said interim-length mast arms shall be specially fabricated to provide the correct "theta" angle (see relevant Caltrans Standard Plans) for the required length, compatibility with pole shaft mounting hardware, and provide the structural strength for the required loading.

5.1.) **FLASHING YELLOW BEACONS**

Flashing beacons shall conform to the provisions in Section 86-4.07, "Flashing Beacons," of the Caltrans Standard Specifications, and these Technical Provisions.

If and where called for on the Plans, the Contractor shall furnish and install complete flashing beacon assembly(ies). Assembly(ies) shall include but need not be limited to foundations, anchor bolts, poles, mast arms, mast arm connection hardware, flashing beacon(s), visor(s), backplate(s), signs of proper type and size, sign lighting equipment (including photoelectric control therefor), flashing beacon control assembly, and all other equipment required by Caltrans Standard Drawing ES-9A.

Contractor shall furnish and install one flashing beacon control assembly on each flashing beacon assembly. The flashing beacon control assembly shall be housed in a weatherproof, side-hinged NEMA Type 3R enclosure, the bottom of which shall be 5.0 feet above adjacent ground. The control assembly timer shall be RTC Manufacturing, Inc., Model AP21T.

6.) **CONDUIT**

Conduit shall conform to the provisions in Section 86-2.05, "CONDUIT," of the Caltrans Standard Specifications, and these Technical Provisions.

All conduits, the sizes of which are not shown otherwise on the Plans, shall be minimum 2 inches in diameter.

Unless specified otherwise on the Plans or by the requirements of the first two paragraphs of Section 86-2.05B, "Use", of the Caltrans Standard Specifications, conduit material may be any one of the five types permitted in the Caltrans Standard Specifications:

- 1) Type 1 (hot-dip galvanized rigid steel conduit);

- 2) Type 2 (hot-dipped galvanized and coated rigid steel conduit);
- 3) Type 3 (rigid non-metallic conduit);
- 4) Type 4 (liquid-tight flexible metal conduit); or
- 5) Type 5 (intermediate steel conduit, to be used only where specified on the Plans or in these Special Provisions);

provided, however, that if and where the conduit is to be installed by jacking or water boring, only Type 1 (rigid steel) conduit is acceptable. Type 3 (rigid non-metallic) conduit will be accepted for directional boring method. Insulated bonding bushings will be required on metal conduit.

In addition to the conductors called for in the Conductor Schedule or elsewhere on the Plans, all Type 3 conduit runs not receiving the #8 equipment grounding conductor required by Section 86-2.10, "BONDING AND GROUNDING," of the Caltrans Standard Specifications shall have installed a #14 tracer wire. This wire shall be buried in the terminating pull box and shall terminate in the ground buss in the controller cabinet. Also, in addition to all of the above, all conduit to be installed per the Plans shall include a Pull Rope per Section 86-2.05C, "Installation."

After conductors have been installed, the ends of conduits terminating in pull boxes and controller cabinets shall be sealed with an approved type of sealing compound.

Unless otherwise specified on the Plans, all conduit under street pavement may be installed using the "Trenching in Pavement Method" described in Section 86-2.05C, "INSTALLATION," of the Caltrans Standard Specifications, as amended herein. All Type 3 conduit under street pavement SHALL be installed using either this method or directional boring method.

The 19th paragraph of Section 86-2.05C, "INSTALLATION," of the Caltrans Standard Specifications is hereby amended to read:

Conduit to be placed by the trenching method shall be Type 3. Conduit shall be placed under existing pavement in a trench approximately 50 mm (2 inches) wider than the outside diameter of the conduit to be installed. Trench shall not exceed 150 mm (6 inches) in width. Conduit depth shall not exceed 400 mm (16 inches) or the sum of the conduit trade diameters plus 350 mm (14 inches), whichever is greater; except that at pull boxes, the trench may be hand-dug to the required depth. The top of the installed conduit shall be at least 300 mm (12 inches) below finish grade.

The 22nd paragraph of Section 86-2.05C, "INSTALLATION," of the Caltrans Standard Specifications is hereby amended to read:



The conduit shall be placed in the bottom of the trench and the trench shall be backfilled with cement slurry. Cement slurry backfill shall conform to San Diego Regional Standard Drawing G-34 (Type C). Existing asphalt concrete pavement shall be planed and resurfaced per City of Escondido Standard Drawing G-5-E.

In addition to the above requirements, all conduit to be installed in areas other than under street pavement where trench width is less than 0.3 m (12 inches) shall have their trenches filled up to within 100 mm (4 inches) of finish grade with slurry cement backfill per Section 19-3.062, "SLURRY CEMENT BACKFILL" of the Caltrans Standard Specifications.

NOTE: Conduit to be installed for traffic signal interconnection shall conform to Caltrans standards for fiberoptic communications.

NOTE: All service conduit (between service point and meter pedestal) must meet more-stringent standards than those listed herein. Contractor shall determine and comply with all SDG&E requirements relative thereto, including pre-backfill trench inspection by SDG&E.

#### 7.) **PULL BOXES**

Pull boxes shall conform to the provisions in Section 86-2.06, "PULL BOXES," of the Caltrans Standard Specifications and these Technical Provisions.

All pull boxes, the sizes of which are not shown otherwise on the Plans, shall be minimum #5 size. All pull boxes, the locations of which are not shown on the Plans, shall be placed behind the sidewalk or, if the preceding is impractical, in the sidewalk adjacent to the right-of-way.

All pull box locations shall be considered approximate. The Contractor shall obtain approval of locations by the Engineer prior to construction.

Pull boxes, pull box covers and pull box extensions shall be concrete. Pull boxes shall not be grouted. Six (6) inches of gravel shall be provided underneath all pull boxes, extending six (6) inches past the outer edges thereof on all sides.

Standard Plan Drawing ES-8 "Pull Box Details" shall be amended to delete Notes 4.)a.)5.) and 4.)b.)10.).

NOTE: Pull boxes and splice boxes installed for traffic signal interconnection shall conform to Caltrans standards for fiberoptic communications.

8.) **FUSED SPLICE CONNECTORS**

Fused splice connectors shall conform to the provisions in Section 86-2.095, "FUSED SPLICE CONNECTORS," of the Caltrans Standard Specifications except that connectors shall be installed in the pole base hand hole.

9.) **CONDUCTORS**

Conductors shall conform to the provisions in Section 86-2.08, "CONDUCTORS," of the Caltrans Standard Specifications and these Technical Provisions.

Insulation Type THHN or THWN shall be used for individual conductors.

The first sentence of the second paragraph of Section 86-2.09A, "CIRCUITRY," of the Caltrans Standard Specifications is amended to read:

Except as specifically permitted otherwise by the Plans or the Field Engineering Inspector, all control circuit conductors shall be run continuously without splices from a terminal block located in a cabinet, compartment, or signal head, to a similarly located terminal block.

9.1.) **SIGNAL CABLE**

Signal cable shall conform to the provisions in Section 86-2.08D, "SIGNAL CABLE," of the Caltrans Standard Specifications, and these Technical Provisions.

The 5th paragraph of Section 86-2.08D, "SIGNAL CABLE," of the Caltrans Standard Specifications is hereby amended to read:

The 3-conductor cable shall be used for pedestrian push buttons and a spare, unless its use for vehicle signals, pedestrian signals, signal spares, video camera power, or photoelectric control is specifically called out on the Plans.

9.2.) **SIGNAL INTERCONNECT CABLE**

A. Specifications

Signal Interconnect Cable (SIC) shall be a six (6) paired-conductor communications cable (total 12 conductors) and shall conform to the requirements of REA specification PE-39 (gel-filled cable, solid copper conductors). The conductor gauge shall be 22 AWG or larger.

B Installation

The Contractor shall furnish and install paired-conductor cable as shown on the Plans. The Contractor shall furnish and install all necessary cable, ground

rods, grounding conductors, guying, and all other incidentals necessary for furnishing, installing, and connecting the cable.

Multiple installations of interconnect cable shall be grounded by connecting all cable shielding together. The shield shall be connected to ground at one point only - at the intersection controller cabinet nearest the telephone service point. This method of grounding assures a noise-free environment for the communication conductors.

The Contractor shall provide the Engineer with a color coding / identification plan for interconnection cables which must be approved by the City before any installation starts. The approved color / identification plans shall be used throughout the project in all controllers and for underground and aerial splices.

10.) **BONDING AND GROUNDING**

Bonding and grounding shall conform to the provisions in Section 86-2.10, "BONDING AND GROUNDING," of the Caltrans Standard Specifications and these Technical Provisions.

Grounding jumper shall be attached by a 3/16-inch or larger brass bolt in the signal standard or controller pedestal and shall be run to the conduit, ground rod or bonding wire in adjacent pull box.

Grounding jumper shall be visible after cap has been poured on the foundation.

11.) **SERVICE**

Service shall conform to the provisions in Section 86-2.11, "SERVICE," of the Caltrans Standard Specifications and these Technical Provisions. The Contractor is responsible for scheduling with SDG&E for service details.

Furnish and install Type III-BF Service Equipment Enclosure(s) or modified Type III-CF ("dual-socket") Service Equipment Enclosure(s) with the features, circuits, and breakers shown on the Plans. Where the Plan calls for a Type III-CF enclosure, the second meter shall measure power delivered to the equipment wired thereto (per the proper Meter Pedestal Wiring Diagram) only.

Each safety lighting circuit shall contain a 30-amp, two-pole, 240-volt circuit breaker. The contactor for each safety lighting circuit shall be a 30-amp, two-pole, either a normally-closed, solid-state type or a normally-open, mechanical, electrically-held type. If any circuits are proposed for mid-block street lighting, said circuits shall bypass the intersection safety lighting's photoelectric control and contactor.

The equipment enclosure manufacturer and/or contractor shall ascertain the current San Diego Gas and Electric Company requirements for Service Cabinet dimensions and appurtenances and are solely responsible for compliance with same.

All service enclosures shall be constructed of anodized aluminum or stainless steel.

If so directed by the Plans, the Contractor shall furnish and install a combination meter pedestal and battery back-up unit (Tesco Controls # 27-000/22-000, V.I.T. Products StrongBox #MPE XXX-42K, or approved equal). The Contractor may voluntarily choose this option if there is no direction to the contrary on the Plans. Said combination units shall be accepted by and in full compliance with all requirements of San Diego Gas & Electric Company. Said combination units shall also comply with the other requirements of this Section, the requirements of the Section of these Technical Provisions entitled "BATTERY BACK-UP SYSTEMS", and the Meter Pedestal Wiring Diagram on the Plans (except for addition of BBU power provisions).

Upon approval by the Engineer, Contractor shall contact San Diego Gas and Electric for inspection of conduit and trench for the service run conduit at least 5 working days prior to the inspection date. It shall be the responsibility of the Contractor to obtain San Diego Gas and Electric approval before backfilling. If said approval is not obtained prior to backfilling, Contractor shall provide, at his / her expense, all necessary materials, equipment and labor to furnish and install the service conductors to the Standards required by San Diego Gas and Electric.

#### 11.1.) **TELEPHONE SERVICE**

Where called for on the plans, telephone service shall consist of furnishing and installing all materials, labor, tools, equipment, scheduling with AT&T for service details, and other incidental items required to provide the following.

If and where called for on the Plans, the Contractor shall furnish and install a terminal and splice enclosure on the side of the controller cabinet per the attached Drawing #3. The enclosures (cabinets) shall be 12"x12"x6" (WxHxD) and shall be equal to or better than *Cooper B-line Systems* catalog number 12126 PBRTC. Each enclosure shall be installed with the plywood backing board and shall be furnished with an "SP 60" -type key lock. Contractor shall furnish and install conduit and pull rope, per the Plans and all AT&T requirements, from enclosure to Telephone Service Point. The telephone company will make all of the wiring connections. Contractor shall comply with all service requirements of AT&T and shall coordinate service details and scheduling with same well in advance of need.

NOTE: All telephone service equipment shall be installed, tested, and functioning properly prior to energization of any new traffic signal.

#### 12.) **TESTING**

Testing shall conform to the provisions in Section 86-2.14, "TESTING," of the Caltrans Standard Specifications and these Technical Provisions.

Equipment and materials delivered for testing shall be clearly identified as City of Escondido, and the project location.

The Contractor shall notify the City in writing of the date of delivery for testing at least five days prior to delivery.

The last sentence of the first paragraph of Section 86-2.14A, "MATERIALS TESTING," of the Caltrans Standard Specifications is amended to read:

Materials testing, including testing of new controller assembly(ies), will be performed by the City of Escondido, 475 North Spruce, Escondido, CA 92025, Attention: Daniel Young, (760) 839-4668 ext. 4885. Contractor shall arrange to have controller assembly(ies) delivered to the above address, and shall pick up and deliver to job site after testing.

All other sentences in the Caltrans Standard Specifications which refer to "State Testing" of traffic signal control equipment shall be deemed to refer to testing by the City.

At the City's option, the Contractor shall arrange to have a signal technician, qualified to work on the controller and employed by the controller manufacturer or its representative, present at the time the controller is to be turned on for testing. The 21-day test period shall begin after the controller is turned on by the technician. The technician shall provide suitable training on the operation of the controller.

The controller turn-on shall not be scheduled until all equipment is installed.

Section 86-2.14B, "FIELD TESTING," is amended to include:

Insulation resistance (Megger) test for traffic signal and lighting conductors shall be performed in the following order:

Signals: After conductors are connected to signal head terminals and before connection to controller.

Lighting: Before fuses are installed in fused splice connectors.

Load-side conductors in signal heads shall be disconnected from terminal blocks during the test.

Except for inductive loop detector circuits, the insulation resistance shall not be less than 50 megohms on each signal and lighting circuit.

### 13.) **PAINTING**

Painting shall conform to the provisions in Section 86-2.16, "PAINTING," of the Caltrans Standard Specifications and these Technical Provisions.

The Contractor and manufacturer shall protect the factory applied coating system referred to in Section 86-2.16 "PAINTING." Any damage to the factory finish of any painted equipment shall be touched up with a matching color, at the direction of the Engineer.

14.) **CONTROLLER ASSEMBLY**

New controller assemblies, and modifications to existing controller assemblies, shall conform to the provisions in Section 86-3, "CONTROLLER ASSEMBLIES," of the Caltrans Standard Specifications and these Technical Provisions.

New controllers shall be Model 170E conforming with the provisions of Section 86-3.11 of the Caltrans Standard Specifications.

The 412C EPROM module shall be included with each new controller. Each EPROM shall include the BI Tran 233 program, unless a blank 27256 I.C. chip (to be programmed by City personnel) is specifically called out by the Plans.

Each new conflict monitor shall be model 210E. The Red Monitor Kit shall be included. NOTE: The contractor shall furnish and install a new conflict monitor for all traffic signal modification projects involving a change in intersection phasing.

Each new or modified controller assembly shall be equipped with #222 detector cards, #200 load switches, #242 DC isolators, #204 plug-in flashers, and (if called for on the Plans) video detection equipment (monitor, processor(s), and extension module(s)) of a quantity that will facilitate the intended phasing and operation per the Plans.

Each new controller shall be provided with one G.D.I. brand Model 400 or equal telephone modem. If a fiberoptic modem is also called for on the Plans, the cabinet shall also be provided with an I.F.S. brand Model D9130 or equal fiberoptic modem.

Each new controller cabinet shall contain a separate terminal strip for loop detector lead-in conductors, pre-wired to connect to the detector bay and labeled accordingly.

Each new controller assembly shall contain a document drawer / shelf immediately below the controller unit. Said drawer shall have a top which is hinged at the back.

Detector sensor units shall comply with the requirements in the Section of these Technical Provisions entitled "Detectors."

The three-circuit, solid-state switching devices for signal light circuits shall be constructed using individual encapsulated solid-state relays.

Each new controller cabinet shall be constructed of anodized aluminum.

Where called for on the plans, Contractor shall install Telephone Service per Section 11.1, TELEPHONE SERVICE, of these Technical Provisions.

Contractor shall furnish and install one Communications Terminal Panel in each new Controller Assembly per Section 14.1, COMMUNICATIONS TERMINAL PANEL, of these Technical Provisions.

Contractor shall furnish and install one Battery Back-Up System which is in compliance with Section 14.2, BATTERY BACK-UP SYSTEM, of these Technical Provisions, for each new traffic signal. If the Plans call for addition of Battery Back-Up System to an existing traffic signal, said System shall comply with Section 14.2.

Emergency Vehicle Pre-Empt (E.V.P.E.) Phase Selectors (2 ea. 2-channel, see Section 15 of these Technical Provisions) shall be provided and pre-wired to provide emergency vehicle preemption as shown on the Plans. (Use Slots 12 and 13 of Input File "J.")

Testing of controller assemblies shall be by City personnel; see Section 12. Contractor shall arrange to have controller assemblies delivered to City Yard at 475 N. Spruce Street and pick up and deliver controller assemblies to job site after testing.

#### 14.1.) **COMMUNICATIONS TERMINAL PANEL**

The Contractor shall furnish and install in each new controller cabinet a Communications Termination Panel containing two terminal blocks. The terminal blocks shall provide a mounting location for communications cable, over-voltage protection devices, and the termination points of the C2P harness and connector.

##### A. Panel Construction

1. The panel shall be fabricated from 0.125 inch sheet aluminum.
2. The panel shall be drilled and tapped as necessary to mount the terminal blocks and other attachments described below, as well as to mount the panel to the EIA rack within the cabinet. Sharp edges or burrs caused by the cutting or drilling process shall be removed. Corners shall be rounded with a  $\frac{3}{4}$ " radius.

##### B. Communications Cable Terminal Block (CB-1)

The Communications Cable Terminal Block shall be able to terminate a 6-pair #22AWG communications cable.

##### C. Active Pairs Termination Block (CTB-2)

A six position, dual screw, closed back barrier strip shall be mounted on the Communications Termination Panel. The strip shall be rated at 15 amperes and shall be provided with 6-32 x 1/4 inch nickel plated brass binder head screws.

D. Over-Voltage Protection

1. An over-voltage surge protector shall be provided on each of the active communications cable pairs terminating in the cabinet. The protectors shall be installed on the Active Pairs Termination Block (CTB-2).
2. The surge protector shall be a plug-in module capable of clamping the input and output voltage to within plus and minus 8 VDC.

E. Grounding Stud

A grounding stud shall be provided on each panel. The stud shall be extended through the panel. The over-voltage protection devices' ground leads shall be attached to the stud on the front side of the panel. A No. 8 AWG copper conductor shall connect to the stud on the back of the panel and shall connect to the cabinet's Equipment Grounding Bus.

F. C2P Harness and Connector

A 4-conductor jacketed cable shall be furnished and attached to the CTB-2 terminal block with ring lugs. The cable shall terminate in a standard C2P connector and shall be routed through the cabinet and be of sufficient length to reach the C2S connector on the back of the 170E Controller Unit when the unit is installed in the equipment rack.

G. Wiring Detail

The CTB-2 terminal block and the C2 plug shall be wired as shown below:

Terminal Block (CTB-2)		C2 Connector	
	Position	Function	Pin
Audio Protected	1-B	Audio In	A
Audio Protected	2-B	Audio In	B
Audio Protected	3-B	Audio Out	C
Audio Protected	4-B	Audio Out	D



(Spare)	5-B		
(Spare)	6-B		

Terminal block positions are numbered: from left to right starting with 1. Terminals on top are denoted A and those on the bottom are denoted B.

H. Feed-Through Opening

A feed-through opening, complete with protective grommet shall be provided on the panel to protect the C2P harness. A strain relief device shall also be provided.

I. Cable-Tie Openings

Two ¼" diameter holes shall be provided for future installation of cable ties.

J. Attachment to Equipment Rack

The panel shall be securely attached to the equipment rack. It shall be mounted below the output file on the 332 cabinet.

14.2.) **BATTERY BACK-UP SYSTEM**

Contractor shall furnish and install a Battery Back-up System with each new traffic signal, and with traffic signal modification if so directed by the Plans therefor. The batteries shall be housed in a separate, free-standing cabinet, to be field-located near the controller assembly, OR alternatively a combination meter pedestal and battery back-up unit may be furnished and installed (see the section of these Technical Provisions entitled "SERVICE").

All battery back-up systems must be capable of operating in two (2) modes: flash mode (red LEDs) and full normal operation mode (all LED indications). The system shall include a timing circuit allowing automatic switching from full operation to all-red flash at a selectable time interval. NOTE: The system shall arrive initially set-up to automatically switch from full operation to flash mode at 60% battery capacity. The UPS shall have two (2) ea. 5 – 15 receptacles for connecting the controller and other sensitive electronic equipment. The UPS shall include two (2) front panel LCD displays; one to count the number of times the UPS operates on battery and one to count the total elapsed time in battery mode.

All battery back-up systems shall be equipped with all additional equipment required (wiring, relays, isolators, etc.) to enable it to provide and maintain an output signal when the battery back-up system is supplying power to the traffic signal. Said signal shall provide an "Extern3" alarm on the City of Escondido's QuicNet 4 traffic signal control / monitoring system Alarm Report. Contractor shall coordinate with Public

Works Inspector and Electrical Services personnel to demonstrate said alarm function to said City personnel's satisfaction prior to final acceptance.

Battery back-up systems in separate cabinets shall be either Clary Corporation SP Series 1000 Traffic UPS, or Dimension model DUI-24Y11, or approved equal. Battery back-up cabinet shall be per Clary Corporation Fabrication Drawing # 162-13242, or Dimension Fabrication Drawing compatible with DUI-24Y11, or approved equal. Minimum dimensions shall be 42" H x 26" W x 14" D. Construction material shall be anodized aluminum or stainless steel. Location shall be in the general vicinity of the Controller Assembly, as specified by City of Escondido Electrical Services personnel.

15.) **EMERGENCY VEHICLE PRE-EMPT SYSTEMS**

Contractor shall furnish and install Emergency Vehicle Pre-Empt (E.V.P.E.) system(s) as directed by the Plans. Said system(s) shall be the 3M "Opticom" system or approved equal. If the Plans specify a particular brand, the Contractor shall install that specified brand.

3M "OPTICOM" E.V.P.E. systems shall include M752 Optical Detectors of a quantity as shown on the Plan and mounted per the attached Drawing #2, M762 Phase Selectors, and Optical Detector Cable. Phase Selectors (2 each, 2-channel, Model M762) shall be installed and pre-wired into the Controller Assembly (see Section D-14 of these Special Provisions) by the manufacturer / supplier prior to delivery to the City for testing.

Prior to E.V.P.E. detector installation, the contractor shall schedule a meeting with a representative of the E.V.P.E. system manufacturer, to evaluate detector placement. Contractor shall retain flexibility to change mounting locations of E.V.P.E. detectors per suggestions of this representative, and shall do so if so directed by the Public Works Inspector.

Emitter assemblies will not be required. The Contractor shall test the system using City-furnished Class II emitter assemblies. The Contractor shall arrange to have a representative of the E.V.P.E. system manufacturer present during system testing.

Two tests shall be conducted; one using a Class I signal emitter and a distance of 1,000 feet between the emitter and the detector, the other using a Class II signal emitter and a distance of 1,800 feet between the emitter and the detector. All range adjustments on the module shall be set to "Maximum" for each test.

Each above test shall be conducted for a period of one hour, during which the emitter shall be operated for 30 cycles, each consisting of a one minute "on" interval and a one minute "off" interval. During the total test period; (1.) the emitter signal shall cause the proper response from the model 170E controller unit during each "on"

interval; and (2.) there shall be no improper operation of either the Model 170E controller unit or the monitor during each "off" interval.

Emergency Vehicle Pre-empt System cable shall be as recommended by the manufacturer for their system EXCEPT: "S.O." type cable is not acceptable, Contractor shall substitute an equivalent cable that is suitable for installation in underground conduits.

16.) **SIGNAL FACES AND SIGNAL HEADS**

Signal faces, signal heads and auxiliary equipment, as shown on the Plans, and the installation thereof, shall conform to the provisions in Sections 86-4.01, "VEHICLE SIGNAL FACES," 86-4.03, "DIRECTIONAL LOUVERS," 86-4.04, "BACKPLATES," and 86-4.08, "SIGNAL MOUNTING ASSEMBLIES," of the Caltrans Standard Specifications and these Technical Provisions.

All new vehicular traffic signal indications (red, yellow, and green; arrow and circular) shall be L.E.D. (Light Emitting Diode) signals, and shall be 300 mm (12 inches) diameter. All vehicle indications shall have backplates.

All signal section housings, visors, louvers, backplates, and mounting assemblies (framework) shall be metal.

All exposed metal signal housings, doors, visors, louvers, backplates, and mounting assemblies / framework shall be electrostatically powder-coated by a City-approved process. The minimum requirements for this process shall be:

1. A 3-to-5 stage pretreatment consisting of:
  - a. Degrease
  - b. Rinse
  - c. Iron phosphate
  - d. Rinse
  - e. Seal

NOTE: Items a and c can be combined, thereby eliminating Items c and d and making this a three-stage process.

2. A dry-off cycle for at least ten (10) minutes at 300 degrees to 400 degrees Fahrenheit.
3. Electrostatically applied powder at 75-90KV.
4. Thermal setting cycle for 20 minutes at 400 degrees Fahrenheit.

All parts shall be coated with an ultraviolet-resistant, polyester powder. The only exception is for items of flat black which can be coated with a self-cleaning flat black epoxy.

Contractor shall furnish manufacturer's Certificate of Compliance with City-approved powder coating process prior to installation of equipment.

**16.1.) L.E.D. VEHICULAR SIGNAL INDICATIONS**

All new red vehicle traffic signal indications, both arrow and circular, shall be 300 mm (12 inch) diameter L.E.D. signals, and shall comply with Section 86-4.02 of the Caltrans Standard Specifications.

All new yellow and green vehicle traffic signal indications, both arrow and circular, shall be 300 mm (12 inch) dia. L.E.D. signals. Contractor shall furnish and install either GE Lumination brand or Dialight brand L.E.D. signals, the model number of which shall be on the Caltrans Pre-Approved Products List, or approved equal.

Contractor shall obtain approval of any "or equal" submittals prior to ordering. Approval will be based upon the submitted product brand and model being listed on the Caltrans Pre-Qualified Products List, OR upon certification by an Independent Testing Laboratory that the submitted product and manufacturing processes / quality control therefor both meet the requirements of the Caltrans Purchase Specification for L.E.D. Yellow and Green Vehicle Signals. Both the Pre-Qualified Products List and the Purchase Specification are posted on the Caltrans website.

**16.2.) L.E.D. PROGRAMMED-VISIBILITY SIGNAL INDICATIONS**

All new programmed-visibility vehicle traffic signal indications, both arrow and circular, shall have L.E.D. light sources. Contractor shall furnish and install either GE Lumination brand, Electro Technology brand, or Dialight brand L.E.D. P.V. signal head clusters, the model number of which shall be on the Caltrans Pre-Approved Products List, or approved equal.

Contractor shall obtain approval of any "or equal" submittals prior to ordering. Approval will be based upon the submitted product being listed on the Caltrans Pre-Qualified Products List, OR upon certification by an Independent Testing Laboratory that the submitted product and manufacturing processes / quality control therefor both meet the requirements of the Caltrans Purchase Specification for L.E.D. Programmed-Visibility Vehicle Signals. Both the Pre-Qualified Products List and the Purchase Specification are posted on the Caltrans website.

**17.) L.E.D. PEDESTRIAN SIGNALS**

All new pedestrian signals shall be L.E.D. signals (both red "Upraised Hand" and white "Walking Person" symbols). Symbols shall be side-by-side, and full (not outline) display. Contractor shall furnish and install either GE Lumination brand,

Electro Technology brand, or Dialight brand, the model number of which shall be on the Caltrans Pre-Approved Products List, or approved equal. Contractor shall obtain approval of any "or equal" submittals prior to ordering. Approval will be based upon the submitted product being listed on the Caltrans Pre-Qualified Products List, OR upon certification by an Independent Testing Laboratory that the submitted product and manufacturing processes / quality control therefor both meet the requirements of the Caltrans Purchase Specification for L.E.D. Pedestrian Signals. Both the Pre-Qualified Products List and the Purchase Specification are posted on the Caltrans website.

17.1.) **AUDIBLE PEDESTRIAN SIGNALS**

If Audible Pedestrian Signals are called for on the Plans, they shall conform to the following.

Audible signals shall be furnished and installed as shown on Plans. The signals should be designed and fabricated to meet the following specifications:

1. The size shall be 6.5 inches high and 5.25 inches diameter.
2. The unit shall operate at 115 Volt AC  $\pm$  15 percent, 60 Hz and 3 Watts.
3. The audio output shall be 90 dB per watt at one meter. The output shall be self-switching to one of two adjustable output levels depending on ambient noise conditions.
4. The unit shall operate at minus 20 to plus 60 degrees centigrade and 40 to 90 percent relative humidity.
5. The output shall be achieved by continuous frequency vibrations as follows:

	East/West <u>("Peep-Peep")</u>	North/South <u>("Cuckoo-Cuckoo")</u>
Duration	0.2 Sec. $\pm$ 20%	0.6 Sec. $\pm$ 20%
Frequency Base	2800 Hz $\pm$ 20%	1100 Hz $\pm$ 20%
Frequency Deviation	-800 Hz $\pm$ 20%	+120 Hz $\pm$ 20%

6. The audible signal equipment shall be factory painted "Traffic Signal Green."
7. All wiring which is external to the audible unit shall be of the "S.O." type.
8. The units shall be mounted so as to direct audible output toward pedestrian across the street, i.e., in nearly horizontal position.

**D-18 VEHICLE DETECTION**

**D-18.1 INDUCTIVE LOOP DETECTORS**

If Inductive Loop Detectors are called for on the Plans, they shall conform to the requirements in "Traffic Signal Control Equipment Specifications" issued by the State of California Department of Transportation and all addenda thereto current at the time of project advertising, the provisions of Section 86-5.01, "VEHICLE DETECTORS" and these Technical Provisions.

Type E (6 ft. dia.) detector loops which are adjacent to limit lines shall have four (4) windings of loop wire each.

Loop wires shall be Type 2.

Loop detector lead-in cable shall be Type B.

Inductive loop detector sensor units shall be of the two channel type, manufactured by either the I.C.C. Company or the E.D.I. Company.

Loop detector sealant shall be Hot-Melt Rubberized Asphalt Sealant.

Bicycle detector loops shall be 3-foot by 6-foot Type Q, unless shown / sized otherwise on the Plans. Contractor shall have the option of installing two 3' diameter circular loops in lieu of each 3'x6' Type Q (bicycle) detector loop shown on the plans, at no extra cost to the City. Both 3' diameter loops shall be connected to the same DLC at the pull box. The loops shall be separated by 4' in lieu of typical 10' spacing. Each loop shall have four windings.

**18.1A.) INDUCTIVE LOOP DETECTOR INSTALLATION**

Loop detector installation shall conform to the provisions in Section 86-5.01A(5), "INSTALLATION DETAILS," of the Caltrans Standard Specifications and these Technical Provisions.

Any existing inductive loop detectors which are damaged by the Contractor's operations shall be replaced within 48 hours; see the Section of these Technical Provisions entitled "SCHEDULING OF WORK."

Prior to loop detector mark-out, Contractor shall insure that all utility covers (manhole lids, gate valve covers, etc.) have been raised to finish grade, and that all final paving and asphalt repair have been completed.

All loop detector locations shall be considered approximate. Detector loop saw slots shall be laid out and painted on the roadway by Contractor. Obtain approval of the Engineer prior to saw-cutting. The additional length of loop wire between loop and

lead-in cable shall be twisted together into a pair (at least 2 turns per foot) before being placed in the slot and conduit to termination pull box.

Where sawed slots cross two different types of pavement material or a concrete- or slurry-backfilled conduit trench (see Sec. D-06), or two different panels of P.C.C. pavement, a 3/4-inch PVC pipe shall be installed across the joint, as shown in "Curb Termination Details Type B" on Caltrans Standard Plan ES-5E, to contain the loop conductors and act as an expansion / deflection fitting.

Splices in loop detector circuits shall not be allowed.

## 18.2.) **NON-INVASIVE, MAGNETO-INDUCTIVE VEHICLE DETECTORS**

If and where the Plans call for non-invasive magneto-inductive vehicle detectors, they shall conform to the requirements of this Section and the notes on the Plans.

Each location shall consist of sensors (2 each for each lane less than 14 ft. in width, and 3 each for each wider lane), mounted in interlocking carrier trays that shall slide freely within a 3-inch-diameter conduit. The sensors shall be capable of converting changes in the vertical component of the earth's magnetic field into changes in inductance that can be detected by a specialized inductive loop detector sensor unit. The sensors for a particular lane at a particular location shall be connected in series, and connected to a standard Type B Detector Lead-in Cable (BDLC) that connects without splices to the input bay of a standard 332 controller cabinet. The sensors and specialized sensor units shall be capable of detecting all licensable vehicles containing ferromagnetic material when they are within a travel distance of one-half (1/2) of the height of said ferromagnetic material. The sensor shall be suitably sealed for use in 100% humidity environment in the conduit.

The sensor unit shall snap into the carrier. The carrier shall hold and maintain the sensor within 20 +/- degrees of vertical. The carrier shall allow for six (6)-inch sensor spacing increments. The transverse spacing of the sensors for a given lane shall be per the Manufacturer's recommendations. The centroid of the sensors for a given lane shall be in the center of the lane unless dimensioned otherwise on the Plans. The first carrier (end cap carrier) shall have a rope attached of sufficient strength to assist in the removal of all the carriers from the conduit. The carrier shall hold up to twelve (12) lead-in cables and the pull rope. The carriers shall enable horizontal placement of detectors to within three (3) inches of the location(s) specified on the plans.

The conduit shall be 3-inch (nominal), Schedule 80 PVC. The conduit shall be installed transversely to the roadway at a nominal centerline depth of 21 inches below the finished roadway surface. Centerline depth shall be maintained between 18 and 24 inches (finish grade to centerline). Deviations in conduit alignment shall be less than 0.25 inches per foot. The outer end of the conduit shall extend three (3) inches into a #6 pull box with extension.

The specialized sensor units shall be per recommendations of the manufacturer of the non-invasive, magneto-inductive vehicle sensors. Contractor shall furnish and install 3M Canoga sensor units or approved equal. Approval of any alternative will be based upon satisfaction of the following provisions, and upon proof of acceptable operation via in-service testing prior to final acceptance of the work. Sensor units shall also be adjustable to function with input from standard inductive loop detectors (Type E) on a per-channel basis. Sensor units shall be mountable in a standard 332 cabinet input file, and shall be capable of providing delay and extension timing, and shall be self-tuning, on all channels. Each sensor unit shall have a single, switched oscillator system to sequentially excite and measure each channel so as to prevent crosstalk between channels within a unit.

Non-invasive, magneto-inductive vehicle sensors will be performance-tested by the Contractor in the presence of the Field Engineering Inspector using a 100-cc-displacement motorcycle. All corrective work necessary to obtain satisfactory performance therewith shall be at the expense of the Contractor.

### 18.3.) **VIDEO DETECTION**

If and where the Plans call for video detection, the contractor shall furnish and install a modular (single camera per approach), rack-mounted video detection system conforming to the following requirements.

#### **1. General**

This specification sets forth the minimum requirements for a system that detects vehicles on a roadway using only video images of vehicle traffic.

##### **1.1 System Hardware**

The video detection system shall consist of one video camera, a video detection processor (VDP) which mounts in a standard detector rack, and a detector rack mounted extension module (EM), for each approach which is to be provided with video detection; and one video monitor. All system hardware assembly shall be performed in the United States.

##### **1.2 System Software**

The system shall include software that detects vehicles in multiple lanes using only the video image. Detection zones shall be defined using only a video menu and a pointing device to place the zones on a video image. Up to 24 detection zones per camera shall be available.

#### **2. Functional Capabilities**



- 2.1 The VDP shall process video from one source. The source can be a video camera or video tape player. The video shall be input to the VDP in RS170 format and shall be digitized and analyzed in real time.
- 2.2 The VDP shall detect the presence of vehicles in up to 24 detection zones per camera. A detection zone shall be approximately the width and length of one car.
- 2.3 Detector zones shall be programmed via a menu displayed on a video monitor and a pointing device (a three button mouse) connected to the VDP. The menu shall facilitate placement of the detection zones. A separate computer shall not be required for programming detection zones.
- 2.4 The VDP shall store up to three different detector zone patterns. The VDP can switch to any one of the three different detector patterns within 1 second of user request via menu selection with the pointing device.
- 2.5 The VDP shall detect vehicles in real time as they travel across each detector zone.
- 2.6 The VDP shall have an RS232 port for communications with an external computer.
- 2.7 The VDP shall accept new detector patterns from an external computer through the RS-232 port.
- 2.8 The VDP shall send its detector patterns to an external computer through the RS-232 port when requested.
- 2.9 The extension module (EM) shall be available to avoid the need to rewire the detector rack, by enabling the user to plug an extension module into the appropriate slot in the detector rack. The extension module shall be connected to the VDP by a 10 wire cable with modular connectors, and shall output contact closures in accordance with user selectable channel assignments.

### **3. Vehicle Detection**

- 3.1 A minimum of 24 detection zones shall be supported and each detection zone can be sized to suit the site and the desired vehicle detection region.
- 3.2 A single detection zone shall be capable to replace multiple loops and detection zone may be ANDed or ORed together to indicate vehicle presence on a single phase of traffic movement.

- 3.3 Placement of detection zones shall be done by using only a pointing device and a graphical interface built into the VDP to draw the detection zones on the video image from each video camera.
- 3.4 Up to 3 detection zone patterns shall be saved within the VDP memory and this memory shall prevent loss during power outages.
- 3.5 The selection of the detection zone pattern for current use shall be done through a menu. It shall be possible to activate a detection zone pattern for a camera from VDP memory and have that detection zone pattern displayed within 1 second of activation.
- 3.6 When a vehicle is detected crossing a detection zone, the detection zone will flash a symbol on the screen to confirm the detection of the vehicle.
- 3.7 Detection shall be at least 98% accurate in good weather conditions and at least 96% accurate under adverse weather conditions (rain, snow, or fog). Detection accuracy is dependent upon site geometry, camera placement, camera quality and detection zone location, and these accuracy levels do not include allowances for occlusion or poor video due to camera location or quality.
- 3.8 Detector placement shall not be more distant from the camera than a distance of ten times the mounting height of the camera.
- 3.9 The VDP shall provide up to 8 channels of vehicle presence detection through a standard detector rack edge connector and one or more extension modules.
- 3.10 The VDP shall provide DZR to enable normal detector operation of existing zones except the one being added or modified during the setup process. The VDP shall output a constant call on any detection channel corresponding to a zone being modified.

#### **4. VDP and EM Hardware**

- 4.1 The VDP and extension module shall be specifically designed to mount in a standard detector rack, using the edge connector to obtain power and provide contact closure outputs. No adapters shall be required to mount the VDP in a standard detector rack. No detector rack rewiring shall be required.
- 4.2 The VDP and extension module shall operate satisfactorily in a temperature range from -34C to +60C and a humidity range from 0%RH to 95%RH, non-condensing.
- 4.3 The VDP and extension module shall be powered by 24 volts dc.

- 4.4 VDP power consumption shall not exceed 450 milliamps. The EM power consumption shall not exceed 100 milliamps.
- 4.5 The VDP shall include an RS232 port for serial communications with a remote computer. This port shall be a "D" subminiature connector on the front of the VDP.
- 4.6 The VDP shall utilize flash memory technology to enable the loading of modified or enhanced software through the RS232 port and without modifying the VDP hardware.
- 4.7 The VDP and extension module shall include detector output pin out compatibility with industry standard detector racks.
- 4.8 The front of the VDP shall include detection indications for each channel of detection that display detector outputs in real time when the system is operational.
- 4.9 The front of the VDP shall include one BNC video input connection suitable for RS170 video inputs. The video input shall include a switch selectable 75 ohm or high impedance termination to allow camera video to be routed to other devices, as well as input to the VDP for vehicle detection.
- 4.10 The front of the VDP shall include one BNC video output providing real time video output which can be routed to other devices.

## **5. Camera**

- 5.1 The video camera used for traffic detection shall be furnished by the VDP supplier and shall be qualified by the supplier to ensure proper video detection system operation.
- 5.2 The camera shall produce a useable video image of the bodies of vehicles under all roadway lighting conditions, regardless of time of day. The minimum range of scene luminance over which the camera shall produce a useable video image shall be the minimum range from night time to day time, but not less than the range 0.5 lux to 10,000 lux.
- 5.3 The camera shall use a CCD sensing element and shall output video with resolution of not less than 350 lines vertical and 380 lines horizontal.
- 5.4 The camera shall include auto-iris control or automatic electronic shutter control based upon average scene luminance.

- 5.5 The camera shall include a variable focal length lens with variable focus and zoom that can be adjusted, without opening up the camera housing, to suit the site geometry.
- 5.6 The camera electronics shall include AGC to produce a satisfactory image at night.
- 5.7 The camera shall be housed in an environmentally sealed enclosure.
- 5.8 The camera enclosure shall be equipped with a sun shield that prevents sunlight from directly entering the lens. The sunshield shall include a provision for water diversion to prevent water from flowing in the cameras field of view. The camera enclosure with sunshield shall be less than 6" diameter, less than 26" long, and shall weigh less than 12 pounds when the camera and lens are mounted inside the enclosure.
- 5.9 The camera enclosure shall include a thermostatically controlled heater to assure proper operation of the lens iris at low temperatures and prevent moisture condensation on the optical faceplate of the enclosure.
- 5.10 When mounted outdoors in the enclosure, the camera shall operate satisfactorily in a temperature range from -34C to +60C and a humidity range from 0% RH to 100% RH.
- 5.11 The camera shall be powered by 120 VAC 60 Hz. Power consumption shall be less than 40 watts under all conditions. NOTE: All video cameras shall be individually fused.
- 5.12 Recommended camera placement shall be 33 feet (or 10 meters) above the roadway, and over the traveled way on which vehicles are to be detected. The camera shall view approaching vehicles at a distance not to exceed 350 feet for reliable detection.
- 5.13 The camera enclosure shall be equipped with separate, weather-tight connections for power and video cables at the rear of the enclosure to allow diagnostic testing and viewing of video at the camera while the camera is installed on a mast arm or pole. Video and power shall not be connected with the same connector.
- 5.14 The video signal output by the camera shall be in RS170 format.
- 5.15 The video signal shall be fully isolated from the camera enclosure and power cabling.

## **6. Installation**

- 6.1 Coaxial cable for transmission of video signals shall be Belden #8281 or equivalent. This cable shall be suitable for installation in conduit or overhead with appropriate span wire. BNC plug connectors should be used at both the Camera and Cabinet ends. The coaxial cable, BNC connector and crimping tool shall be approved by the supplier of the video detection system and the manufacturer's instructions must be followed to ensure proper connection.
- 6.2 The power cabling shall be 16 AWG three conductor cable. The cabling shall comply with the National Electric Code, as well as local electrical codes. NOTE: "S.O." type cable is not acceptable, Contractor shall substitute an equivalent cable that is suitable for installation in underground conduit.
- 6.3 The video detection system shall be installed as recommended by the supplier and as documented in installation materials provided by the supplier. NOTE: The Contractor shall arrange to have a representative of the video detection manufacturer present during camera mounting.

## **7. Warranty**

- 7.1 The video detection system shall be warranted to be free of defects in material and workmanship for a period of two years from date of shipment from the supplier's facility. During the warranty period, the supplier shall repair with new or refurbished materials, or replace at no charge, any product containing a warranty defect provided the product is returned FOB to the supplier's factory or authorized repair site. Product repaired or replaced under warranty by the supplier will be returned with transportation prepaid. This warranty does not apply to products damaged by accident, misuse, abuse, improper operation, service by unauthorized personnel, or unauthorized modification.
- 7.2 In recognition of the substantial influence on video detection performance exerted by the quality of the physical installation, including selection of locations for cameras as well as cabling and connector integrity, no warranty of merchantability or fitness for purpose is made for the video detection system. Under no circumstances shall supplier be liable for any loss or damage, whether direct, indirect, special, incidental, or consequential, to the contracting agency or any third party arising out of the use or inability to use the products..
- 7.3 The foregoing warranties are expressly made in lieu of all warranties expressed or implied and are the sole remedy of customers.
- 7.4 During the warranty period, technical support shall be available from the supplier via telephone within 4 hours of the time a call is made by a user,

and this support shall be available from factory certified personnel or factory-certified installers.

- 7.5 During the warranty period, updates to VDP software shall be available from the supplier without charge.

## **8. Maintenance and Support**

- 8.1 The supplier shall maintain an adequate inventory of parts to support maintenance and repair of the video detection system. These parts shall be available for delivery within 30 days of placement of an acceptable order at the supplier's then current pricing and terms of sale for said parts.
- 8.2 The supplier shall maintain an ongoing program of technical support for the video detection system. This technical support shall be available via telephone, or via personnel sent to the installation site upon placement of an acceptable order at the supplier's then current pricing and terms of sale for on site technical support services.
- 8.3 Installation or training support shall be provided by a factory authorized representative.
- 8.4 All product documentation shall be written in the English language.

## **19.) PEDESTRIAN PUSH BUTTON ASSEMBLIES**

Pedestrian push buttons shall conform to the provisions in Section 86-5.02, "PEDESTRIAN PUSH BUTTON ASSEMBLIES," of the Caltrans Standard Specifications and these Technical Provisions.

Pedestrian push button assemblies shall be Type B. Instructional signs therefor shall be 9" x 12" nominal size for Type 19 and larger poles, and shall be 5" x 7" nominal size for other poles. The instructional signs shall be the International symbol type.

## **20.) LUMINAIRES**

Luminaires on traffic signal standards shall be 180 watt Low Pressure Sodium with Type II, II-S, or III distribution. All luminaires shall have polycarbonate lenses. Use Spaulding Lighting, Inc., #PR-180 LOPS-CL-MA, or Pacific Lighting, Inc., #RW-180-GL-120/240, or Visionaire Lighting, Inc., #RDW-3-T3-180L-240-MAF-GY-PER-TB-RBT-w/LAMP, flat full-cutoff luminaries, complying with the following Technical Provisions.

The luminaire housing shall be fabricated of heavy gauge aluminum sheet and plate with concealed welds. The optical and ballast compartments shall be individually accessible for service and inspection. The ballast compartment door and lens shall have full perimeter closed cell neoprene gaskets and quarter turn fasteners. The exte-

rior metal surfaces shall be finished with a gray baked on electrostatic polyester powder paint.

Both the transformer and the ballast shall be mounted internally, i.e., neither shall be mounted to any access door.

Photoelectric control shall be Type II. The photoelectric cell therefor shall be Fisher-Pierce brand; mount on top of pole so designated in the Pole and Equipment Schedule on the Plan. The contactor therefor shall be the "electrically-held" type.

20.1.) **RELOCATE EXISTING ORNAMENTAL STREET LIGHT(S)**

If and where called for on the Plans, existing ornamental street lights shall be relocated. This work shall include furnishing and installing all new equipment necessary to re-energize the lights per Escondido Standard Drawing E-1-E, including but not limited to construction of new anchor base foundations at the new locations, transporting of existing street lights from old to new locations, erecting and plumbing of existing street lights on new foundations, construction of pull boxes and conduit sweeps next to new street light locations, and connection to conductors / conduit to an SDG&E-approved or City-approved power source.

21.) **TRAFFIC-SIGNAL-MOUNTED SIGNS AND MOUNTING BRACKETS**

Mast arm mounted street name signs and left turn control signs shall be furnished and installed, or relocated, per the Plans.

Street Name Signs

Street name signs shall be 8 inch upper case and 6 inch lower case white reflective letters and border on a green background. The general sign composition shall follow the G7(CA) sign. The message size and letter style shall conform to M.U.T.C.D. Standards (Series D or thicker). The legend shall be as shown on the Plans or as otherwise approved by the Engineer. The sign size shall be as shown in the Caltrans Standard Plans.

Sign material shall be white cut-out letters and border on green sheeting. Use 3M Diamond Grade Sheeting.

All signs shall be double-faced unless specifically called-out otherwise on the Plans.

Each street name sign shall consist of two separate sign panels (aluminum alloy 3003-H14 or 5052 - H32, thickness 0.050") securely attached to closed aluminum channel frame (alloy 6063-T5, 1.25" x 1.25" x 0.125" thick). Corners of frame shall be mitered at a 45° angle; all three joined faces shall be welded on the inside of the frame so as to insure structural soundness and watertightness. Mount sign panels on outside of frame with anodized aluminum rivets (3/16" dia., alloy 5052, 1/2" min. edge clearance); exposed faces of rivets shall be compatible with face color of sign.

### Mounting Brackets for Street Name Signs

NOTE: The following examples and dimensions / adjustment ranges thereon notwithstanding, it is the Contractor's and Supplier's joint responsibility to insure that the mounting brackets furnished and installed for street name signs can be adjusted so that the street name signs are level; and it is the Contractor's responsibility to install signs level and mounting brackets plumb.

Mounting brackets for street name signs shall be fabricated of galvanized or stainless steel and may be of three types or as approved by the Engineer:

1. Mounting brackets similar to Caltrans Standard Drawing ES-70, notes 1, 2, 5 through 12, 26, and 27 (View E-E); or
2. Drawing No. 1 as shown attached to this Specification; or
3. A modification of #1 or #2 above to include a three-piece telescoping "L" bracket, subject to approval of the Engineer (Safeway Signs EZ-L or approved equal).

All street name sign brackets for this project shall be of the same type.

### Left or U-Turn Control Signs

Left turn control signs to be furnished and installed shall be of the size and Series shown on the Plans. The signs shall be installed prior to energizing the signal.

### Mounting Brackets for Turn Control Signs

Brackets for mounting left turn control signs shall be in accordance with detail U of Caltrans Standard Plan Sheet ES-7N, or as otherwise approved by the Engineer.

## 22.) **SALVAGE EXISTING TRAFFIC SIGNAL CONTROL AND LIGHTING EQUIPMENT**

Salvaging existing traffic signal control and lighting equipment shall conform to the provisions of Section 86-7, "REMOVING, REINSTALLING OR SALVAGING ELECTRICAL EQUIPMENT," of the Caltrans Standard Specifications and these Technical Provisions.

Existing traffic signal and / or ornamental street light standards that are to be salvaged per the Plans shall be delivered to the City Yard at 475 North Spruce Street. Other miscellaneous equipment thereon may also need to be salvaged.

Existing foundations for salvaged or relocated street lights shall be removed or abandoned in accordance with the Section of these Technical Provisions entitled "ABANDON STREET LIGHT FOUNDATION(S)." Existing foundations for



salvaged or relocated traffic signal standards shall be removed per Section 86-2.03 of the Caltrans Standard Specifications. The Contractor shall remove and replace all sidewalk adjacent to the existing foundation to the nearest score line or expansion joint.

23.) **ROADWAY MARKINGS**

Roadway Markings, and the removal thereof, shall be performed as directed by the Plans, in accordance with Section 84, "TRAFFIC STRIPES AND PAVEMENT MARKINGS," and Section 15, "EXISTING HIGHWAY FACILITIES," of the Caltrans Standard Specifications and these Technical Provisions.

The Contractor shall remove existing pavement markings and traffic striping, including existing raised pavement markers adjacent thereto, as directed on the Plans. The wet sandblasting method will be required, except where existing material is thermoplastic; in this latter case, grinding and skin-patching will be acceptable.

After removal of existing delineation, Contractor shall skin-patch areas of sandblasted pavement so as to remove any hint of old delineation. After tacking heavily, Contractor shall apply Class D2 Asphalt Concrete (per Sec. 203-6.3.2 of the Standard Specifications for Public Works Construction) at least three (3) feet wide, centered over area of removed stripe, and compact with roller. At the discretion of the Engineer, the Contractor may substitute a sand-seal of the entire width of the roadway, for the entire length of removed delineation.

Contractor shall lay-out and paint new traffic stripes and pavement markings as directed on the Plans. Material for all new traffic stripes and pavement markings shall be paint, unless thermoplastic legends are specifically called out on the Plans. Contractor shall be solely responsible for insuring that all materials and installation procedures used comply with all applicable Federal, State, Regional, and Local regulations therefor.

The Engineer shall approve the Contractor's alignment and layout for traffic stripes and pavement markings prior to painting. The Contractor shall allow at least two (2) full working days for inspection by the Engineer prior to painting. If the Engineer requires any corrections to alignment / layout, the Contractor shall make such corrections and allow for another two (2) full working days for re-inspection. Any traffic stripes or pavement markings painted without approval of the Engineer shall be removed and re-painted at the Contractor's expense.

City of Escondido pavement markings that are different from Caltrans standard pavement markings shall be painted using City of Escondido stencils. The Contractor shall verify with the Engineer which pavement markings (if any) require the use of City stencils. Where required, the Contractor shall make arrangements with the Engineer to borrow City of Escondido stencils.

Nothing in these Technical Provisions shall relieve the Contractor from his responsibilities as provided in Section 7-1.09, "PUBLIC SAFETY," of the Caltrans Standard Specifications.

24.) **RAISED PAVEMENT MARKERS**

Raised pavement markers and the installation thereof, shall be in accordance with Section 85, "PAVEMENT MARKERS," of the Caltrans Standard Specifications and these Technical Provisions.

Within 48 hours of completion of painting of new traffic striping and markings, the Contractor shall furnish and install new raised pavement markers on the new striping, as shown on the Plans and the Caltrans Standard Plans and Detail Numbers referenced thereon.

If, for any reason, there will be a period of time after removal of existing striping and painting of new striping, during which public traffic will use all or a portion of any roadway in the project area, the Contractor shall provide temporary delineation with "chip seal markers" (Henberger Company, white (one-way), Type W, and yellow (two-way), Type Y, Temporary Pavement Markers, both types with reflective strips; or approved equal). These markers shall be either white or yellow, as directed by the Public Works Inspector, and shall be on maximum 24-foot centers. The markers will be placed either on the old lines which were just removed or on the layout lines for the new striping, as directed by the Public Works Inspector. The furnishing and installing of these markers shall be in addition to any other delineation (cones, signs, barricades, etc.) which are required for public safety. After the Contractor has painted the new striping, the Contractor shall remove and dispose of these temporary markers.

Nothing in these Technical Provisions shall relieve the Contractor from his responsibilities as provided in Section 7-1.09, "PUBLIC SAFETY," of the Caltrans Standard Specifications.

25.) **SIGNING**

Signing shall be in accordance with Section 56, "SIGNS", of the Caltrans Standard Specifications and these Technical Provisions.

Contractor shall remove and salvage, relocate, and / or furnish and install traffic signs as directed on the Plans.

All signs to be removed and salvaged shall be delivered to the City Yard at 475 N. Spruce Street. Contractor shall protect said signs, and is responsible for any damage thereto between start of Contract work and delivery of signs to City.

All new signs that are to be installed on new posts, and all existing signs that are to be relocated (except to street light poles), shall be permanently mounted per San Diego Regional Standard Drawing # M-45. All new signs, and all existing signs to be

relocated, that are to be mounted on street light poles shall be mounted using 2 – ¾” stainless steel clamps and ¼” stainless steel capscrews. Bottom of signs shall be a minimum of seven (7) feet above adjacent ground / sidewalk.

Nothing in these Technical Provisions shall relieve the Contractor from his responsibilities as provided in Section 7-1.09, "PUBLIC SAFETY," of the Caltrans Standard Specifications.

CITY OF ESCONDIDO STREET NAME SIGN BRACKET DETAILS DRAWING NO. 1

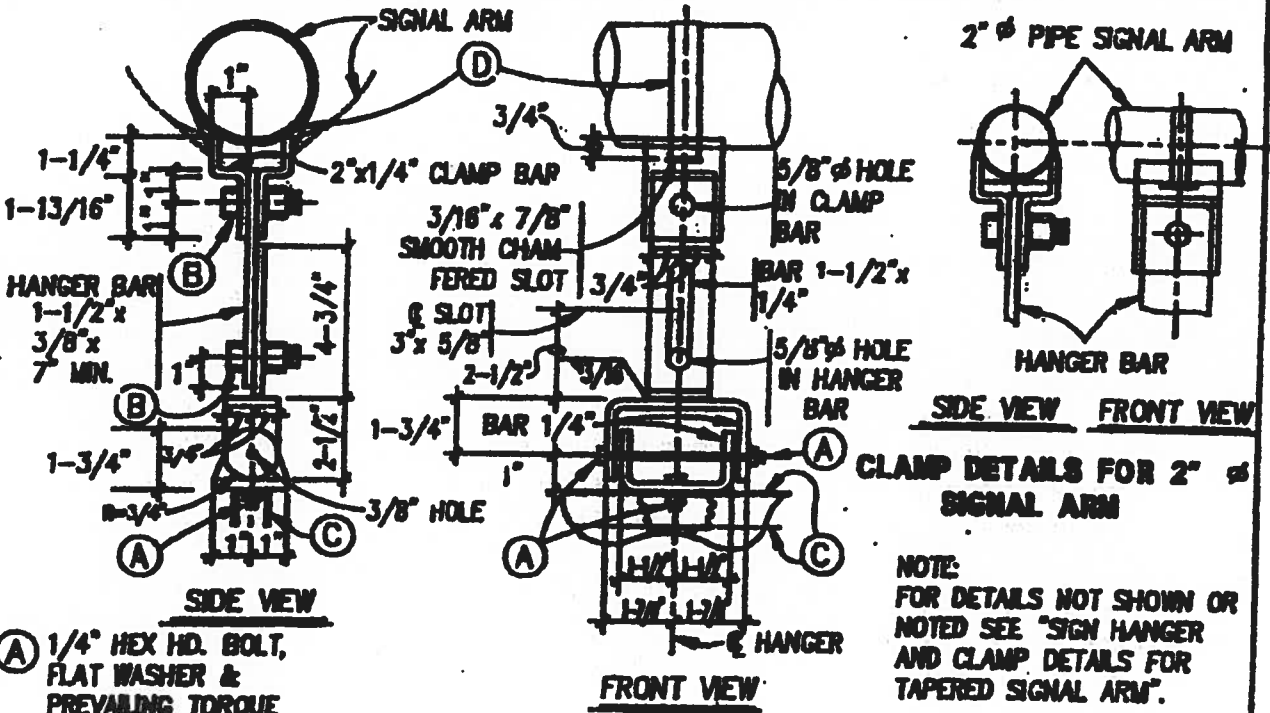

- (A) 1/4" HEX HD. BOLT, FLAT WASHER & PREVAILING TORQUE LOCK NUT.
- (B) 1/2" HEX HD. BOLT, FLAT WASHER & PREVAILING TORQUE LOCK NUT.
- (C) ALUMINUM CHANNEL FRAME (SEE SPEL. PROV. SEC. D-20)

- (D) 3/4" x .03 STAINLESS STEEL BAND DOUBLE WRAP (SECURELY TIGHTENED).

**SIGN HANGER AND CLAMP DETAILS FOR TAPERED SIGNAL ARM**

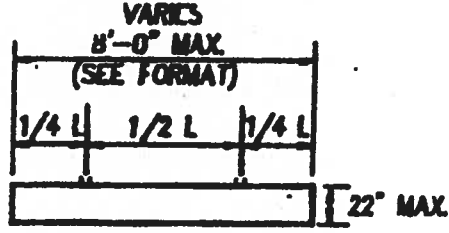

**HANGER SPACINGS**

1. ALL COMPONENTS TO BE GALVANIZED, EXCEPT STAINLESS STEEL BAND.
2. VARY HANGER BAR LENGTH AS REQUIRED TO CLEAR SIGNAL ARM AND TO HANG LEVEL.

**CLAMP DETAILS FOR 2" PIPE SIGNAL ARM**

NOTE: FOR DETAILS NOT SHOWN OR NOTED SEE "SIGN HANGER AND CLAMP DETAILS FOR TAPERED SIGNAL ARM".

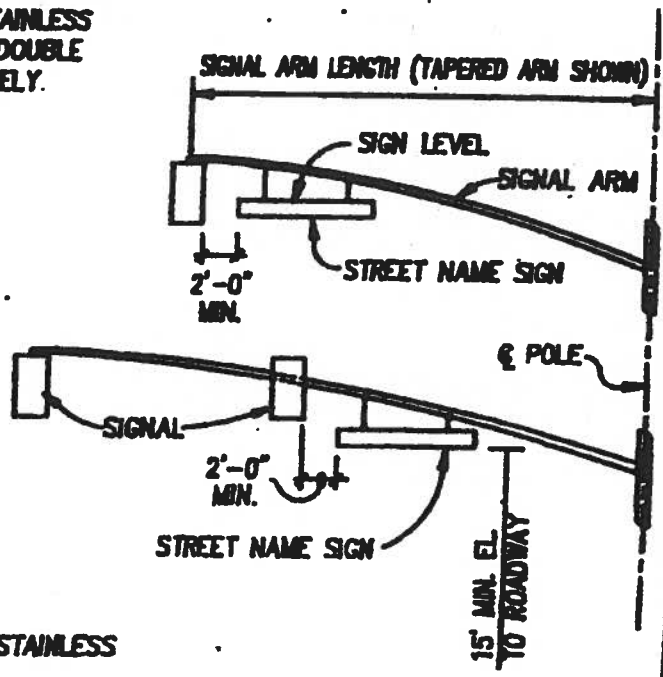

**ELEVATIONS**

CITY OF ESCONDIDO  
TRAFFIC SIGNAL TECHNICAL PROVISIONS  
DRAWING NO. 2

**E.V.P.E. DETECTOR MOUNTING DETAIL**

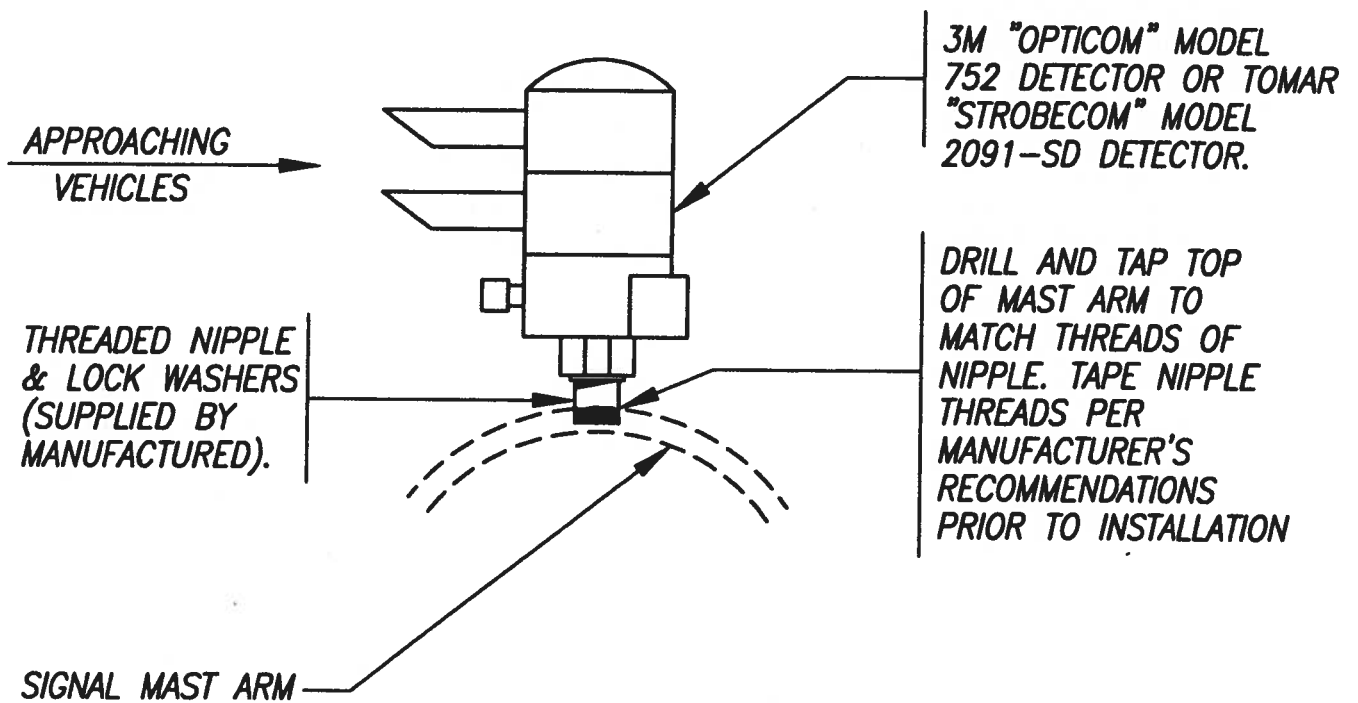

**NOTE:**

ASTRO AB-121 MINI-BRACKET OR  
EQUAL ALSO ACCEPTABLE IF  
SPECIFIED ON PLAN.

CITY OF ESCONDIDO  
TRAFFIC SIGNAL TECHNICAL PROVISIONS  
DRAWING NO. 3

TELEPHONE COMPANY DEMARCATION POINT

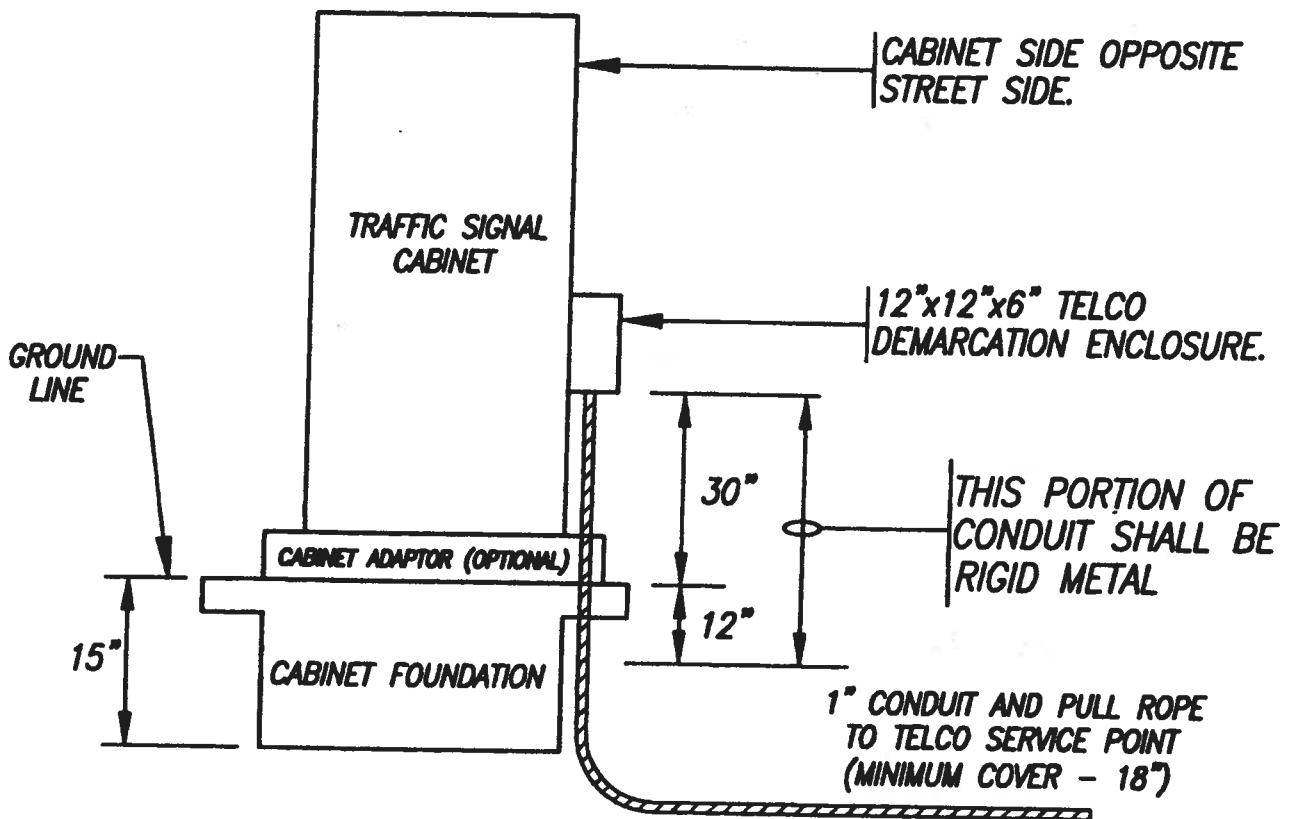

**NOTES:**

1. THE DEMARCATION ENCLOSURE WILL HOUSE TELCO DMS-150 COILS AND PROTECTOR.
2. THE LOCATION WILL BE CONFIRMED BY CITY INSPECTION IN THE FIELD.
3. CONDUIT MAY ENTER CABINET VIA FOUNDATION IF ALLOWED BY AT&T REPRESENTATIVE.

DRAWING #4

# ABANDON ORNAMENTAL STREET LIGHT FOUNDATION

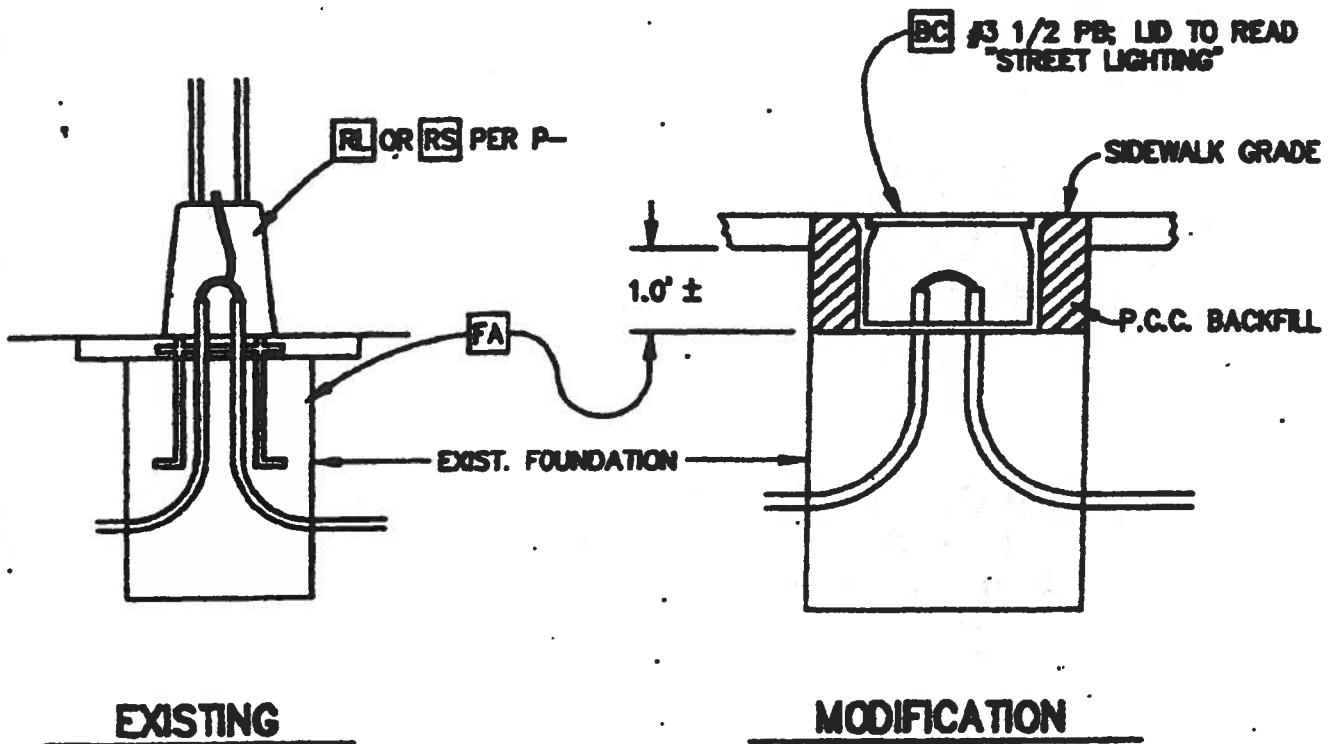

CITY OF ESCONDIDO  
TRAFFIC SIGNAL SPECIAL PROVISIONS

DRAWING # 5

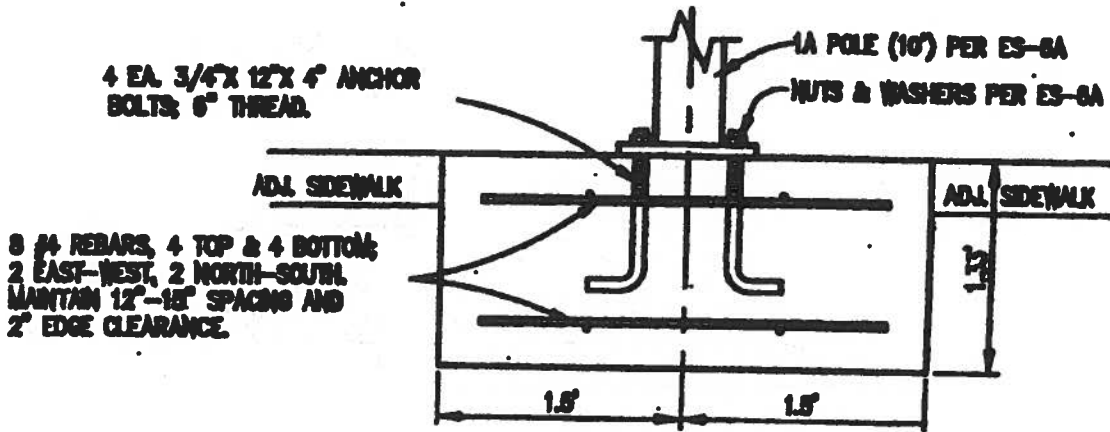

**SPECIAL FOUNDATIONS DETAIL FOR  
1A TRAFFIC SIGNAL POLES WITH  
SHALLOW VERTICAL CLEARANCE FROM  
EXISTING UNDERGROUND UTILITIES**

NOTE: TO BE USED ONLY WITH ADVANCE APPROVAL OF  
PUBLIC WORKS INSPECTOR.